

Pit Mounted Vehicle Restraint SLP3000 and HH3000 Vehicle Restraints

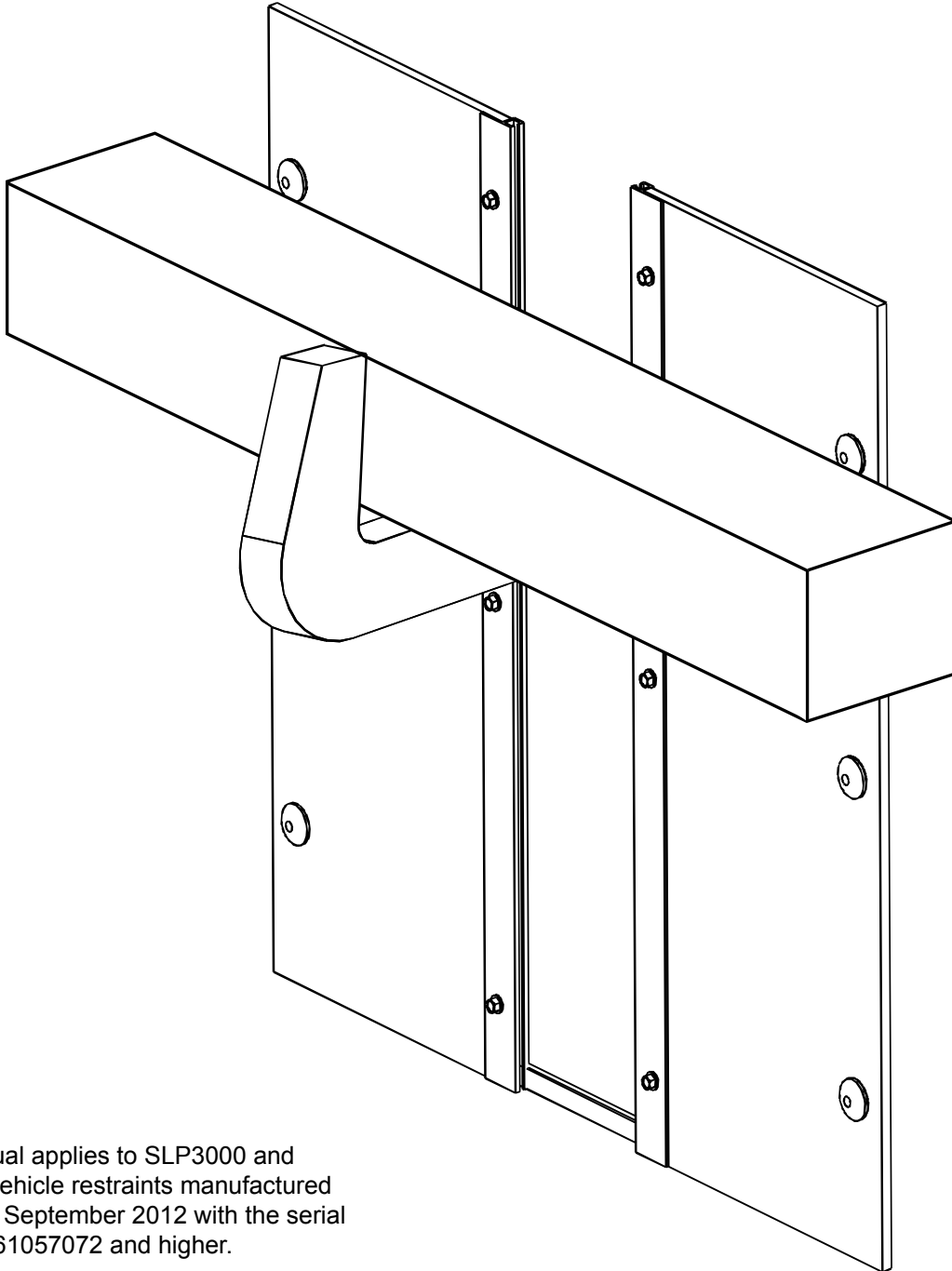

This manual applies to SLP3000 and HH3000 vehicle restraints manufactured beginning September 2012 with the serial numbers 61057072 and higher.

▲ WARNING

Do not install, operate or service this product unless you have read and understand the Safety Practices, Warnings, Installation and Operating Instructions contained in this User's Manual. Failure to do so could result in death or serious injury.

User's Manual Installation, Operations, Maintenance and Parts

Part No. 6011489B

TABLE OF CONTENTS

Introduction.....	2	Solenoid and Proximity Switch Locations.....	20
Safety Signal Words.....	2	Wiring Diagram.....	21
Safety Practices.....	3	Hydraulic Schematic.....	24
Installation.....	4	PLC Diagnostics.....	25
Trailer Presence Sensor (Optional).....	12	Troubleshooting.....	30
Start-Up Test.....	13	Parts List.....	34
Operating Instructions.....	17	Warranty Information.....	47
Planned Maintenance.....	19	Distributor Information.....	48

INTRODUCTION

Welcome and thank you for choosing this vehicle restraint.

This User's Manual contains information that you need to safely install, operate and maintain the vehicle restraint. It also contains a complete parts list and information about ordering replacement parts. Please keep and read this User's Manual before using your new vehicle restraint.

SAFETY SIGNAL WORDS

You may find safety signal words such as DANGER, WARNING, CAUTION or NOTICE throughout this User's Manual. Their use is explained below:



This is the safety alert symbol. It is used to alert you to potential personal injury hazards. Obey all safety messages that follow this symbol to avoid possible death or injury.

▲ DANGER

Indicates an imminently hazardous situation which, if not avoided, will result in death or serious injury.

▲ WARNING

Indicates a potentially hazardous situation which, if not avoided, could result in death or serious injury.

▲ CAUTION

Indicates a potentially hazardous situation which, if not avoided may result in minor or moderate injury.

NOTICE

Notice is used to address practices not related to personal injury.

SAFETY PRACTICES

⚠ WARNING

Read these safety practices before installing, operating or servicing the vehicle restraint. Failure to follow these safety practices could result in death or serious injury.

READ AND FOLLOW THE OPERATING INSTRUCTIONS IN THIS MANUAL BEFORE OPERATING THE VEHICLE RESTRAINT. If you do not understand the instructions, ask your supervisor to teach you how to use the vehicle restraint.

Improper installation of vehicle restraint could result in death or serious injury to dock workers or other users of the vehicle restraint.

Be certain to follow the installation instructions in this manual.

INSTALLATION AND OPERATION

Use by untrained people can cause property damage, bodily injury and/or death. Your supervisor should teach you the safe and proper way to use the vehicle restraint. Read and follow the complete OPERATING INSTRUCTIONS on page 17 before use. **DO NOT USE THE VEHICLE RESTRAINT IF IT IS NOT WORKING RIGHT.** Tell your supervisor it needs repair.

Do not operate the restraint with equipment, material, or people directly in front of the restraint.

Keep hands and feet clear of the hook mechanisms at all times. Stay clear of the restraint when it is moving.

Do not load or unload any vehicle unless you make certain the vehicle restraint has securely hitched the vehicle's RIG (rear impact guard) and set the brakes. If the vehicle restraint does not hitch the RIG for any reason, **BE CERTAIN TO MANUALLY CHOCK THE VEHICLE WHEELS BEFORE LOADING OR UNLOADING.**

Before chocking vehicle wheels or engaging the vehicle restraint, dump air from air ride suspensions and set parking brake.

MAINTENANCE AND SERVICE PRECAUTIONS

Before doing maintenance or service be certain that the power is disconnected and properly tagged or locked out. Failure to follow these safety practices may result in death or serious injury.

If the vehicle restraint does not operate properly using the procedures in this manual, **BE CERTAIN TO MANUALLY CHOCK THE VEHICLE WHEELS BEFORE LOADING OR UNLOADING.** Call your local distributor for service.

Place barricades around pit on dock floor and driveway while installing, maintaining or repairing vehicle restraining device.

Do not stand in the driveway between the dock and a backing vehicle.

All electrical troubleshooting and repair must be done by a qualified technician and meet all applicable codes.

Before doing any electrical work, make certain the power is disconnected and properly tagged or locked out.

If it is necessary to make troubleshooting checks inside the control box with power on, **USE EXTREME CAUTION.** Do not place fingers or uninsulated tools inside the control box. Touching wires or other parts inside the control box could result in electrical shock, serious injury or death.

INSTALLATION

TOOLS REQUIRED

- 3/8" Allen Wrench
- 1-1/8" Deep Socket (1/2" Drive)
- 1/2" x 12" lg. Socket Extension
- Torque Wrench (1/2" Drive) - 250 ft lb Capable
- 3/4" Open End Wrench
- 7/8" Open End Wrench
- 15/16" Open End Wrench
- Arc Welder
- Small Slotted Screwdriver (#0)

PRELIMINARY CHECKS

NOTE:

When installing the vehicle restraint with all Kelley® dock levelers, all Serco® AB dock levelers, and all 6' long Serco® hydraulic dock levelers the dock leveler must be built for 24" pit depth.

1. Prepare pit for the vehicle restraint as indicated on the pit drawings (form 6001890). These drawings will confirm or establish: unit location and elevation requirements, control box and light locations, and electrical runs. This pit planning will be done best with the participation of all involved parties (contractor, installer, electrician, end user, etc.). Careful planning is the key to trouble-free installation.

⚠ WARNING

Before installation read and follow the Safety Practices on page 3. Failure to follow these safety practices could result in death or serious injury.

READ AND FOLLOW THE OPERATION INSTRUCTIONS IN THIS MANUAL BEFORE OPERATING THE VEHICLE RESTRAINT. If you do not understand the instructions, ask your supervisor to teach you how to use the vehicle restraint.

Improper installation of the vehicle restraint could result in death or serious injury to dock workers or other users of the vehicle restraint.

Place barricades around pit on dock floor and driveway while installing, maintaining or repairing vehicle restraining device.

Be certain bystanders in the driveway stand clear when vehicle restraint is operated.

Be certain to follow the installation instructions in this manual.

Fig. 1

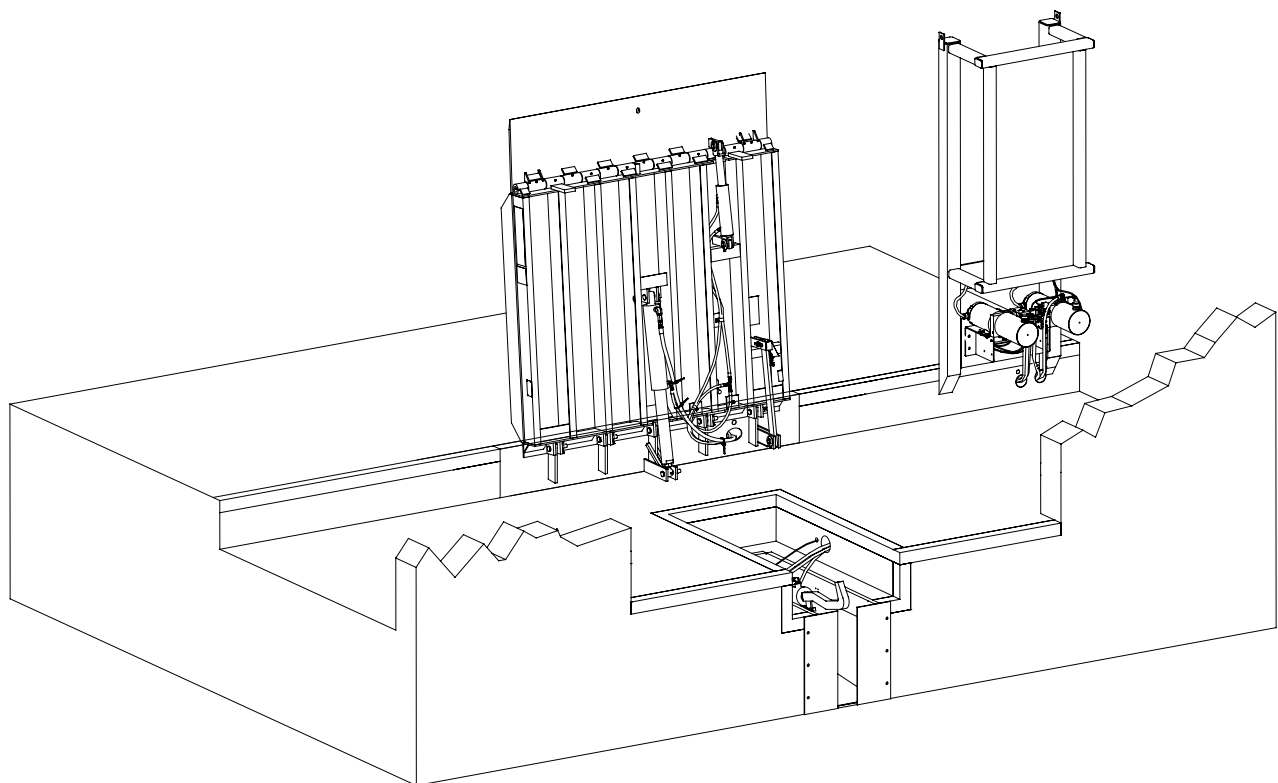

INSTALLATION, continued

- Set the vehicle restraint pan into the pit. Tack weld the crossbar angle (1-1/2" x 40") to the top of the pan to reinforce during concrete pouring. Make sure that the pan is square in the pit and flush with the front dock wall. The bottom front should be flush with grade level. See Fig. 1. Cover the top and front of the unit with heavy poly plastic taped to the box flanges. This will prevent concrete from fouling the restraint mounting face and anchor bolts. Line drill 6 holes 1/2" dia. x 5.5" deep through front face into the front dock wall. Install supplied anchors by hammering them into place.
- Pour concrete around the vehicle restraint pan. Vibrate the pour to ensure complete fill to remove trapped air under and around the pan.

NOTICE

Make sure no concrete enters the pan as this could cause abnormal operation or damage to the unit.

- Allow sufficient time for the concrete to set.
- The proper assembly of the hydraulic cylinders into the restraint box is essential to ensure trouble free operation.

Clean any debris out of the restraint box and off the embed mounting bolts.

Using a hoist and chain lower the hydraulic cylinder assembly into the restraint box over the mounting studs. See Fig. 2.

Slide the assembly flush with embed plate and install the 3/4" flat washer and lock nut (see Fig. 3).

Using a torque wrench, with a min. capacity of 250 ft-lbs, tighten each nut at the required increments of 50 ft-lbs. until the required torque is reached.

Tighten Mounting Nuts to 250 ft lbs.

The hydraulic power unit (HPU) may be located on the left or right side depending on the leveler geometry. The associated tables list the offsets for each leveler used. Fig. 4A shows the HPU installed for most 4Front Engineered Solutions, Inc. dock levelers. Fig. 4B shows the HPU installed in its recommended position for PAL and mechanical levelers.

- Anchor the hydraulic power unit onto the pit floor using the supplied anchor bolts. A minimum of 2 each of the 1/2 x 3-3/4 bolts required through the base flange of the Hydraulic Power Unit (supplied).

Fig. 2

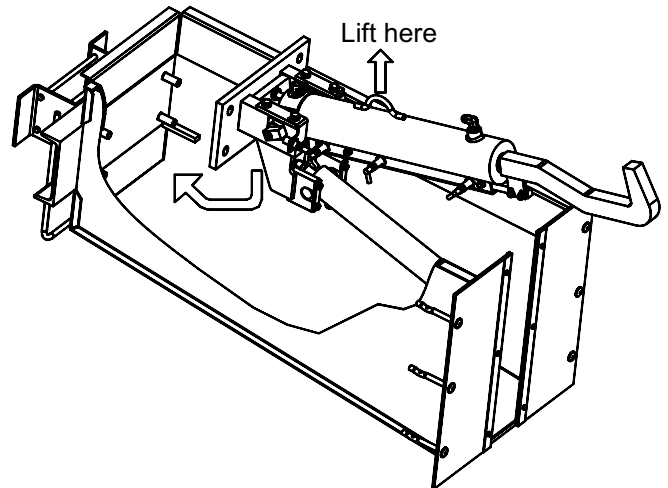
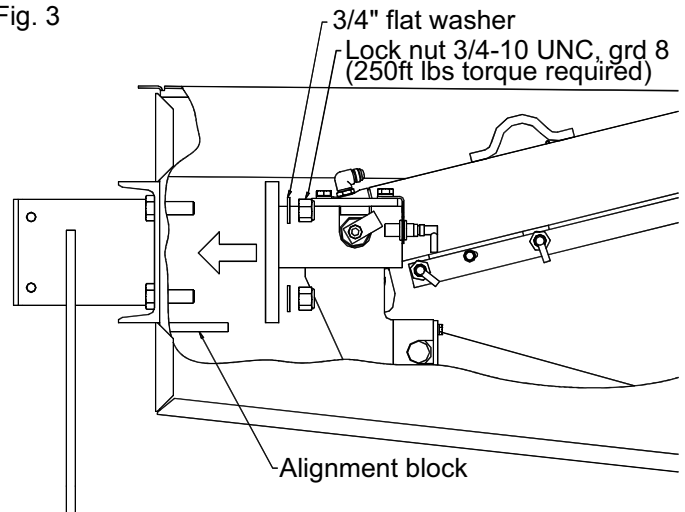
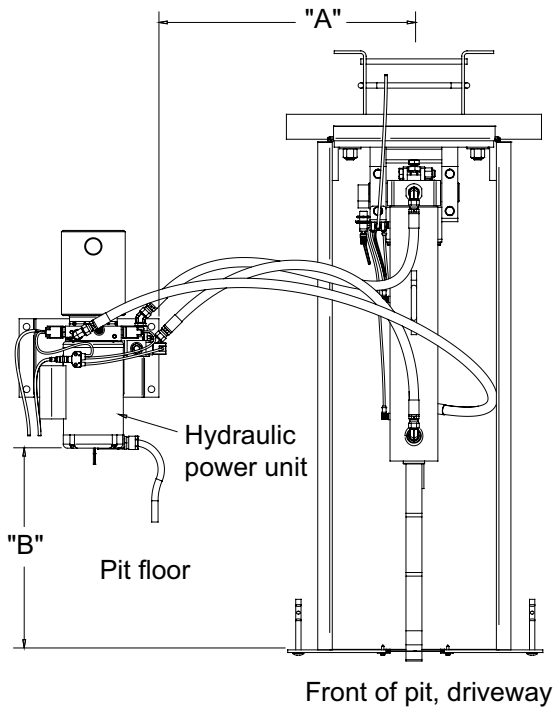

Fig. 3



INSTALLATION, continued

Fig. 4A



KELLEY CM, SERCO WL, WS, PAL

Fig. 4B

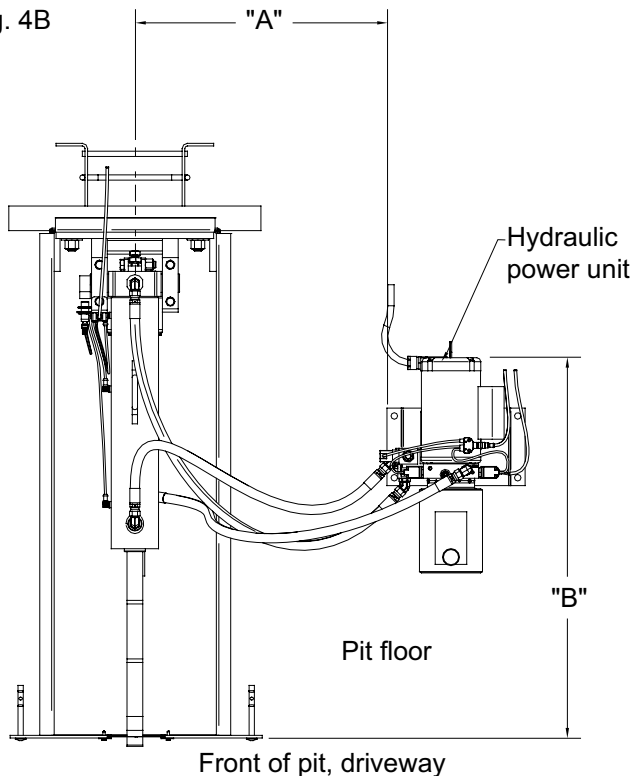

ALL OTHER LEVELERS

Dock Leveler	Leveler Size		Dimension	
	Width	Length	A	B
Kelley® aFX, HP, HK	All	6	16	32
Kelley® aFX, HP, HK	All	8	16	54
Kelley® aFX	All	10	16	80
Kelley® HP, HK	All	10	16	54
Serco® HL, HD, HFC, HLR, HLQ	6	6	22	32
Serco® HL, HD, HFC, HLR, HLQ	6.5 & 7	6	25	32
Serco® HL, HD, HFC, HLR, HLQ	6	8	22	54
Serco® HL, HD, HFC, HLR, HLQ	6.5 & 7	8	25	54
Serco® HL, HD, HFC, HLR, HLQ	6	10	22	54
Serco® HL, HD, HFC, HLR, HLQ	6.5 & 7	10	25	54
Kelley® CM, Serco® WL, WS, PAL	6	6	22	32
Kelley® CM, Serco® WL, WS, PAL	6.5 & 7	6	25	32
Kelley® CM, Serco® WL, WS, PAL	6	8	22	54
Kelley® CM, Serco® WL, WS, PAL	6.5 & 7	8	25	54
Kelley® CM, Serco® WL, WS, PAL	6	10	22	54
Kelley® CM, Serco® WL, WS, PAL	6.5 & 7	10	25	54
Serco® AB	6	6	22	32
Serco® AB	6.5 & 7	6	25	32
Serco® AB	6	8	22	54
Serco® AB	6.5 & 7	8	25	54
Serco® AB	6	10	22	80
Serco® AB	6.5 & 7	10	25	80

NOTE:

6' and 8' Kelley® HK and HP and all Serco® 6' hydraulic dock levelers use 4" riser kit part number 6001844. Assemblies using Kelley® aFX with 24" hook pit box may require a split axle shaft for the pan roller assembly. Reference kit #713-825 and instructions form #5583.

HYDRAULIC INSTALLATION

NOTICE

Dirt or debris in the hydraulic system can hamper proper operation of the vehicle restraint. Do not allow dirt or debris to enter the hoses. If the hoses do become contaminated, remove the line and clean thoroughly before reinstalling.

7. Route the hydraulic lines from the cylinders to the pump manifold as shown in Fig. 6 and 7. Hoses should be neatly dressed.

NOTE:

Elbow fitting on the hold down cylinder must point towards the hydraulic power unit. Loosen jam nut, align elbow fitting appropriately and re-tighten jam nut. See Fig. 5.

8. Remove the plugs and caps from the fittings. Check that all hydraulic fittings are clean and connections are properly connected and tight. These fittings are JIC type fittings and require no thread sealant. If the hoses are too long, coil the excess hose neatly at the base of the power unit and secure with plastic tie straps.

9. Remove the red shipping plug from the hydraulic power unit reservoir and discard. Check that the hydraulic fluid level is full. If not, top off the reservoir to the recommended level shown on page 13. Install the supplied breather cap into the reservoir fill port.

Fig. 6

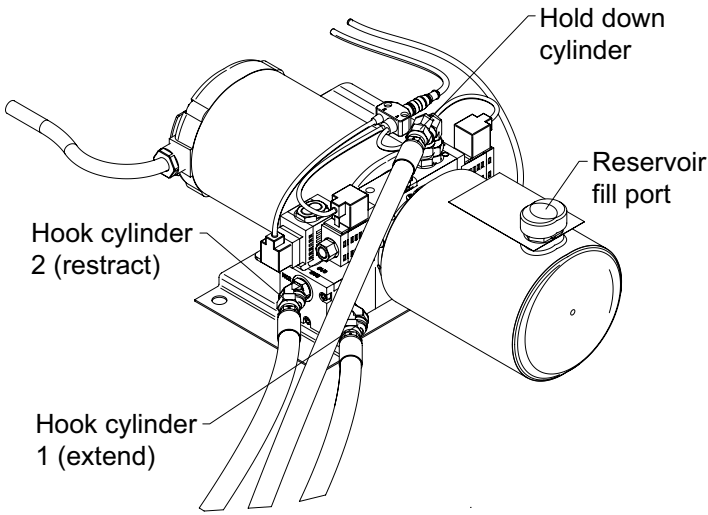
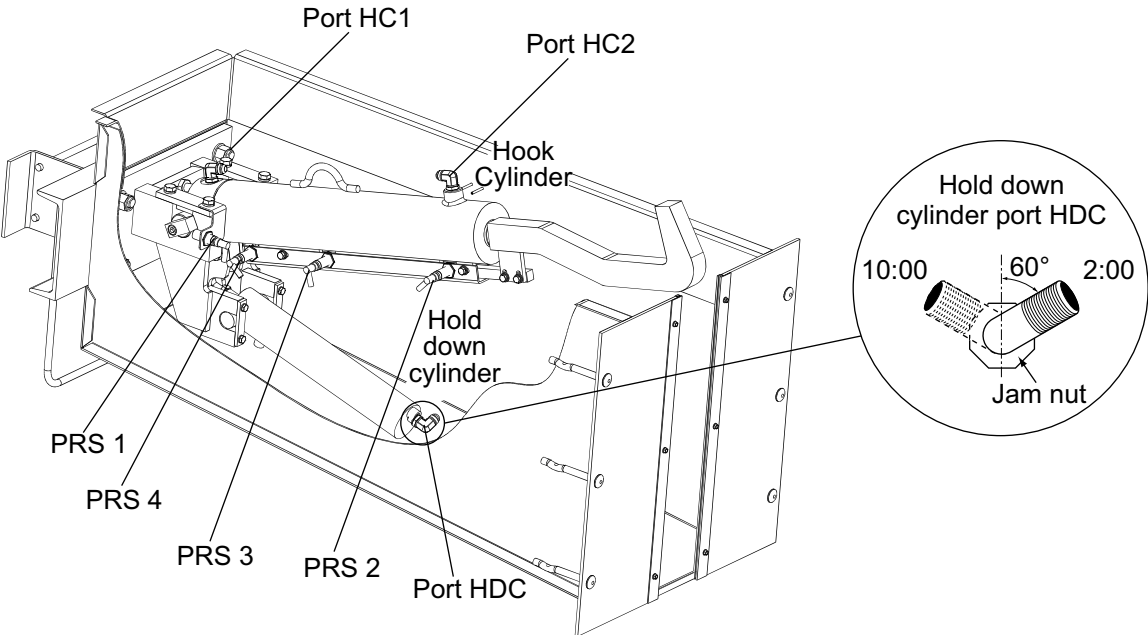

Fig. 5



INSTALLATION, continued

ELECTRICAL INSTALLATION

The electrical wiring for the hook cylinder assembly is managed through cables connecting the proximity switches located under the hook cylinder to the junction box as shown in Fig. 7. Each proximity switch cable is clearly marked and the quick disconnect plug provides simple access and replacement.

▲ DANGER

Before doing any electrical work, make certain the power is disconnected and properly tagged or locked off. All electrical work must be done by a qualified technician and must meet all applicable codes. If it is necessary to make troubleshooting checks inside the control box with the power on, USE EXTREME CAUTION. Do not place fingers or uninsulated tools inside the control box. Touching wires or other parts inside the control box may cause electrical shock, death or serious injury.

High voltage power wires must be run in separate conduit from low voltage control circuit wiring.

▲ WARNING

Before installation read and follow the Safety Practices on page 3. Failure to follow these safety practices could result in death or serious injury.

10. The restraint and power unit are fitted with color coded home run cables for the proximity sensors, pressure switch, and solenoid valves. These cables are 30' long and can be run directly to the control panel. See page 23 Fig. 24.
11. The motor shall be wired directly from the control panel to the motor J-box.

Fig. 7

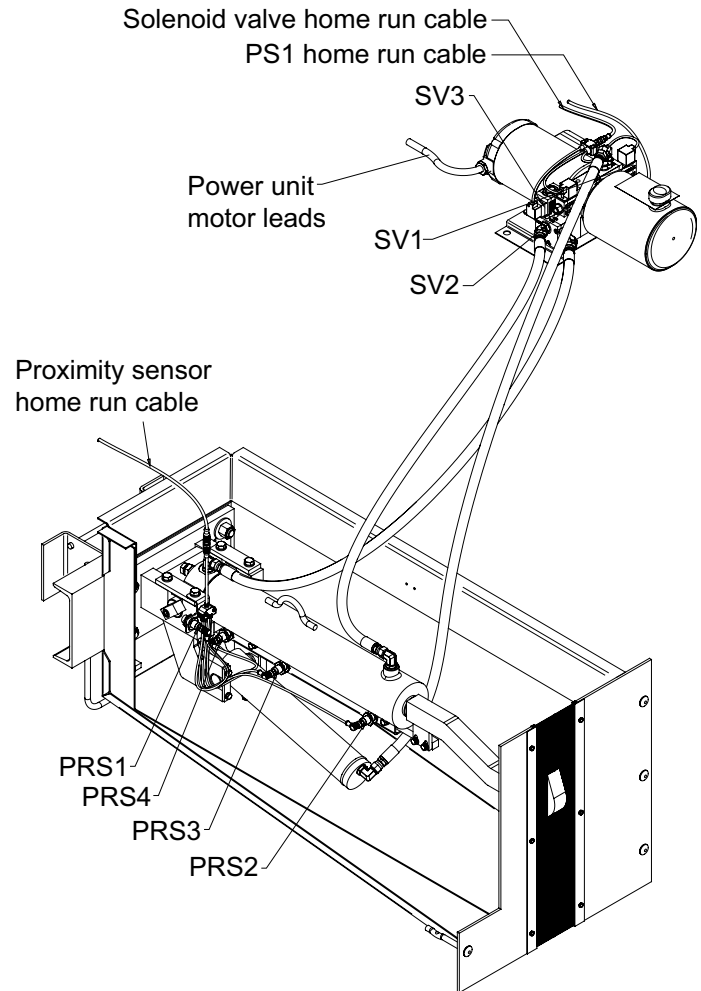

REMOTE MOUNTED POWER UNITS

12. The hydraulic hoses for a remote mount application are longer and shall run through a separate conduit than the proximity sensor's home run cable. See Fig. 8.

NOTE:

Remote mounted power units require 44 oz. of additional hydraulic oil.

Fig. 8

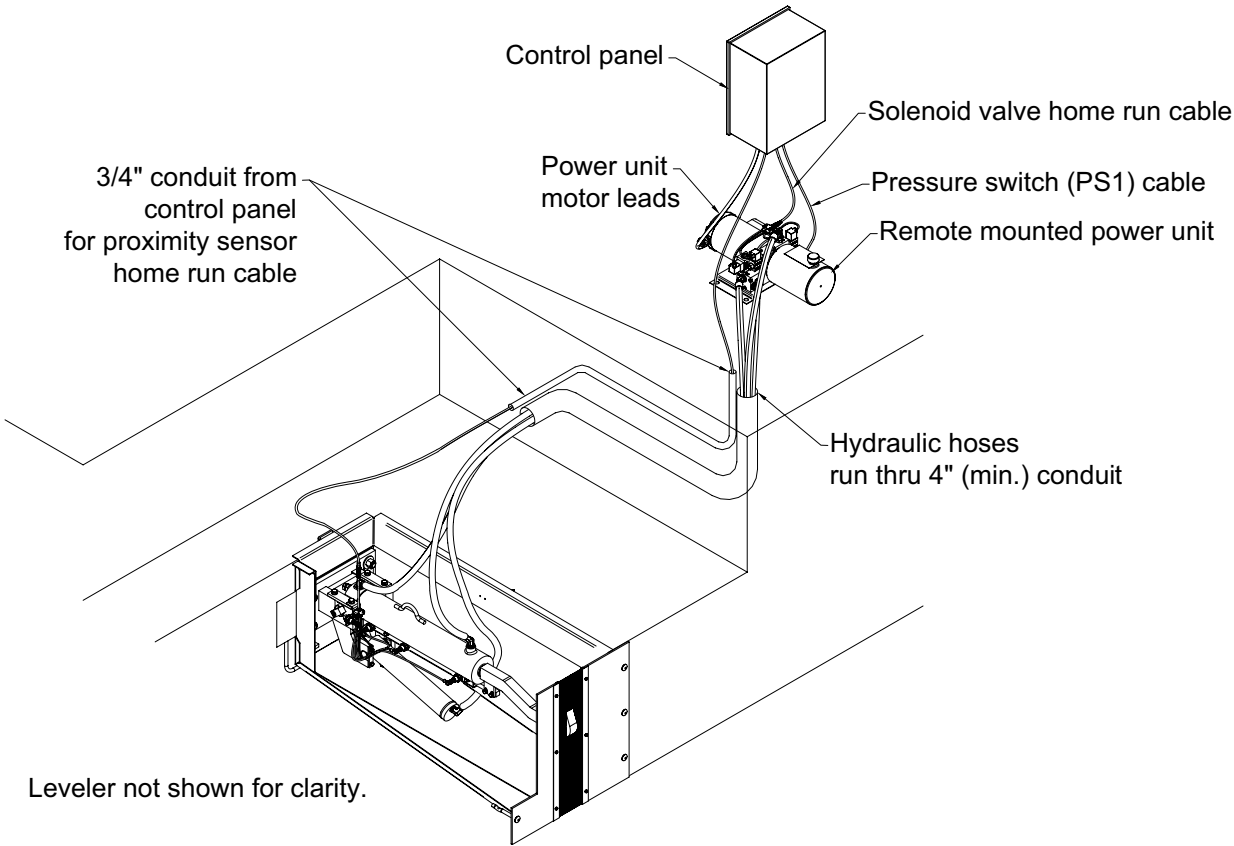

INSTALLATION, continued

16. Mount control box inside the building with the lights centered 60" above the floor, to the left of the doorway. Allow sufficient clearance to dock door track. See Fig. 9.

NOTICE

Connecting 24V lights to the 120V control panel terminals 10, 11, OL1 or OL2 will destroy the light fixture.

NOTE:

For 120V exterior lights, use wiring kit 6003336. Installation instructions are included in the kit.

17. Mount and wire outside 24V LED signal light assembly into the control box to terminals 7 for RED, 8 for GREEN and 9 for common. Terminals are located on the control panel output board. See Fig. 10 and 11. (See Wiring Diagram on page 23.) Make sure when mounting the light assembly that the Red light is on top and the Green light is on the bottom.

18. The Optional Audible Alarm Kit

For Audible Alarm Kit 6003335 installation in control panel.

- 18.1 Remove knockout from bottom of panel. (knockout is approximately 1-1/8" in diameter).

- 18.2 Remove threaded collar from alarm face.

- 18.3 Feed face of Audible Alarm through hole (knockout) from inside the panel.

- 18.4 Screw plastic collar over face of alarm. Tighten collar to secure alarm.

- 18.5 Plug the 2 pin plug into the Output board's Alarm Socket.

Fig. 9

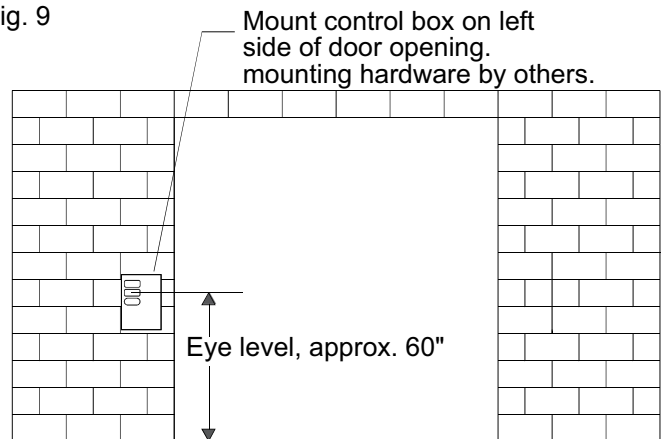

Fig. 10

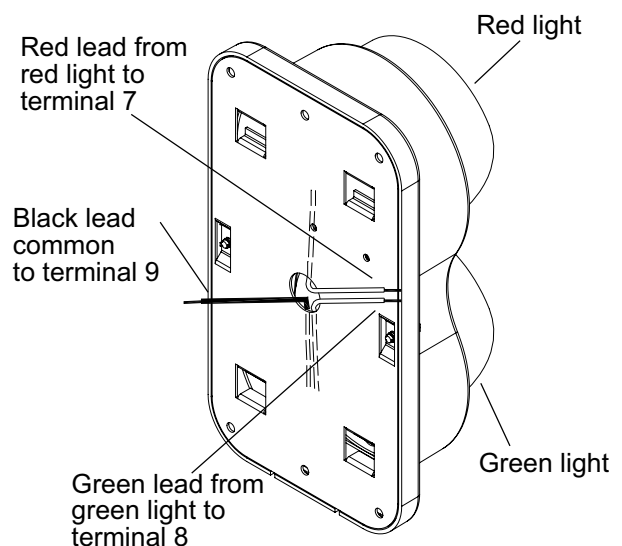
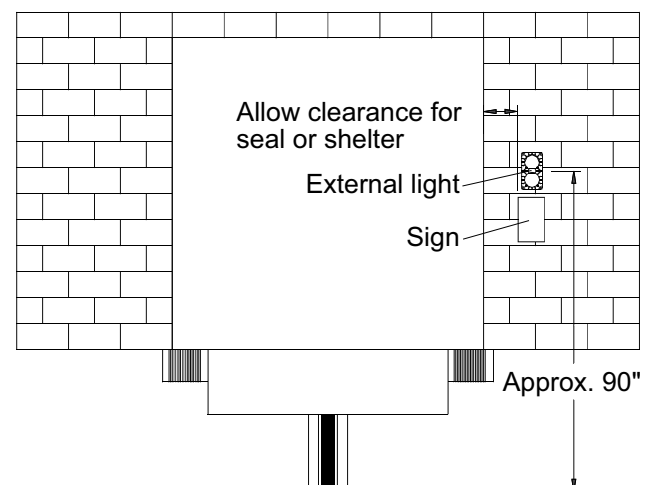

Fig. 11



19. The Leveler Stored Sensor

For leveler stored sensor installation/termination to control panel.

19.1 To enable the leveler stored sensor feature flip the input board dip switch position "3" to the OFF position. Input 10 LED on the PLC will go out.

19.2 The sensor 625-203 is a 4 wire device. First terminate the Positive lead (brown wire) to any "C" terminal on the input board.

19.3 Terminate the Negative lead (blue wire) to any "OV" terminal on the input board.

19.4 Terminate the Load or Switched lead (black wire) to the "19" terminal on the input board.

19.5 Tape (insulate) the unused white wire.

20. The leveler interlock (optional)

For installation of leveler interlock/termination to control panel:

20.1 Identify interlock control circuit wiring from dock leveler (1 pair of wires).

20.2 Terminate these 2 wires from the leveler to terminals 13 and 14 on the output board connector terminals in the control panel.

NOTE:

Termination is not polarity sensitive allowing installation to either terminal with either wire. This interlock circuit is fused at 2 amps.

21. The Vehicle Presence Sensor (Optional)

For vehicle presence sensor installed termination see schematic on page 23.

21.1 The sensor is a 4 wire device. First terminate the positive lead (brown wire) to any "C" terminal on the input board.

21.2 Terminate the negative lead (blue wire) to any "OV" terminal on the input board in the panel.

21.3 Terminate the load lead (black wire) to the "17" terminal on the input board in the panel.

21.4 Tape (insulate) the unused white wire.

22. Permanently mount the vehicle driver's instruction sign on the outside wall under the signal light. Allow sufficient clearance for dock seals/shelters. See Fig. 11.

23. Wire motor to control box. See Wiring Diagram on page 21.

24. Wire solenoids on manifold to control box. Plug electrical cords from junction box into the appropriate solenoid coils. See Wiring Diagram on pages 23.

25. Connect proximity switch cables from junction box to the appropriate terminals in the control box. See Wiring Diagram on pages 23.

26. After wiring motor, solenoids and proximity switches, neatly tie-wrap electrical cords together that go to junction box.

NOTE:

A fused disconnect is required for each vehicle restraint as a means of disconnecting and limiting incoming power to the control box. This disconnect is supplied by others. For correct dual element time delay motor rated fuse size refer to wiring diagram on page 21.

27. Check that the fused disconnect for this installation is a lockable type and meets all applicable electrical and safety codes.

28. Mount the fused disconnect near the control box and wire power to it from an available power source.

29. Run power wires from the fused disconnect to the control box.

30. The vehicle restraint is now ready for start-up and test. Be sure to securely close the control box enclosure at this time.

INSTALLATION, continued

OPTIONAL TRAILER PRESENT SENSOR – LS8 PHOTOELECTRIC

LS8 senses a vehicle at the dock and transmits a signal to the control panel. This turns on the panel face AMBER light. Mount the sensor as shown in Fig. 12 below. Ensure the LS8 sensor's logic switch is set to L/O (Light Operate). The switch is located on the top of the sensor under a plastic cover. Wire the switch. Wire the sensor into the panel per schematic on page 23 and step 21 on page 11. When a vehicle is present at the door, PLC Input 8 will go on.

Fig. 12

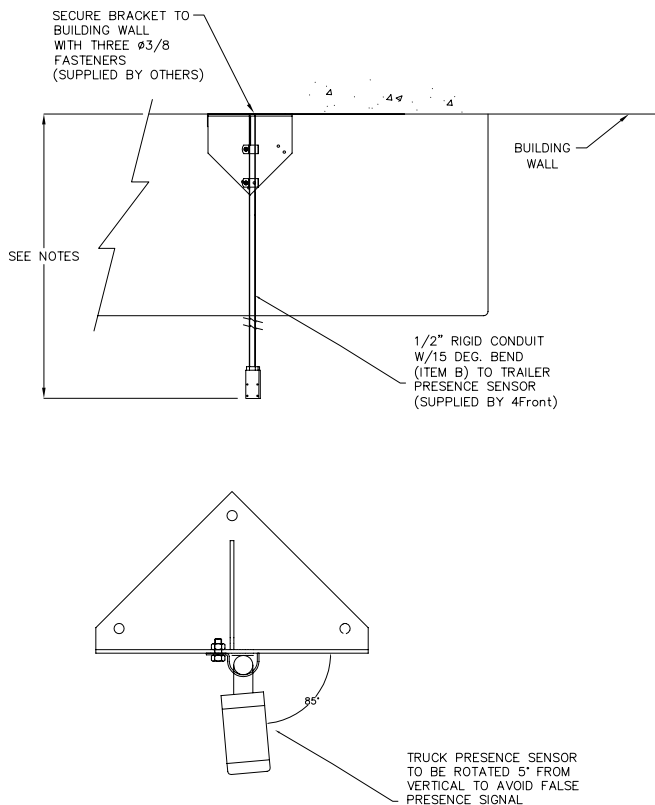

CUT THE UNTHREADED END OF THE 1/2" CONDUIT (ITEM 2) SO THAT THE TRUCK PRESENCE PHOTO-SENSOR DOES NOT SEE THE DOCK SEAL OR SHELTER FLAPS. THIS WILL PREVENT FALSE SIGNALS. IF THERE IS A CANOPY PRESENT, IT IS RECOMMENDED THAT THE PHOTO-SENSOR DOES NOT PROJECT BEYOND THE CANOPY.

ATTACH THE TRUCK PRESENCE PHOTO-SENSOR TO THE THREADED AND BENT END OF THE CONDUIT WITH THE BENT TIP POINTING TOWARDS THE DRIVEWAY.

MAKE SURE THE SELECTOR SWITCH ON THE PHOTO-SENSOR IS SET TO THE "LO" (LIGHT OPERATE) POSITION.

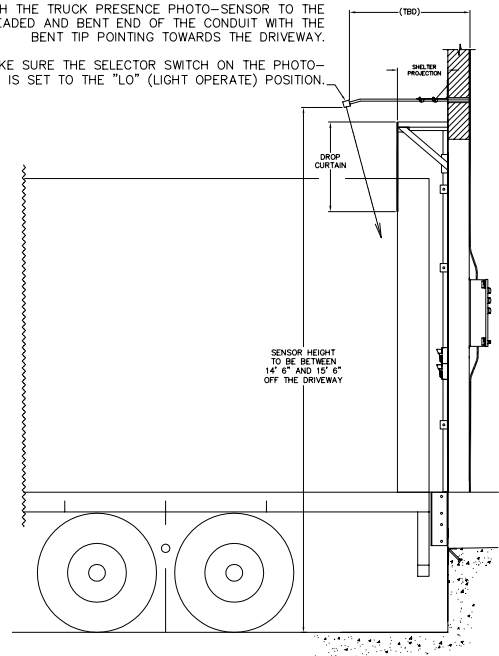

OPERATIONS

No Trailer Present

- Inside lights display Solid RED outside display GREEN.

Trailer Arrives

- Inside lights switch to Solid AMBER and RED, outside lights continue to display GREEN.

Operator engages vehicle restraint

- Inside lights switch to Solid GREEN, outside lights switch to display RED.

Operator releases vehicle restraint

- Inside lights switch to Solid AMBER and RED, outside lights continue to display GREEN.

Trailer Departs

- Inside lights display Solid RED outside display GREEN.

START-UP AND TEST

⚠ WARNING

Do not service this product unless you have read and followed the Safety Practices, Warnings, and Operation instructions contained in this manual. Failure to follow these safety practices could result in death or serious injury.

Before doing maintenance or service, remove power at the fused disconnect. Disconnect must be properly tagged or locked out during maintenance or service of equipment. Failure to disconnect power may result in death or serious injury.

NOTICE

Before putting the vehicle restraint into service, there are preparations and functional checks that must be made. They are:

- 1) Bleeding air from the hydraulic cylinders and lines.**
- 2) Checking operating range of vehicle restraint without vehicle backed into dock.**
 1. Turn power on at fused disconnect.
 2. Activate service mode by simultaneously pressing and holding the **ENGAGE** and **RELEASE** pushbuttons for 5 seconds. Release both pushbuttons as soon as both panel lamps extinguish.
 3. Rotate and release the **RESTRAINT OVERRIDE** switch. Observe PLC input status light #1. If motor rotation is correct, the hold down cylinder should immediately drive the hook cylinder downward, turning on PRS1. If the motor runs and no motion occurs, interchange motor power wires T1 and T2 (three phase motors only).
 4. To clear service mode and return to normal operation, simultaneously press and hold the **ENGAGE** and **RELEASE** pushbuttons for 2 seconds. Alternatively, service mode will exit if no pushbuttons are pressed for 60 seconds. See page 25 for details of service mode.
 5. Push **ENGAGE** pushbutton. The hook should lower, fully extend, fully raise, and partially retract. Finding no vehicle, the hook will extend, fully lower, fully retract into the pit and the alarm (if equipped) will sound. The motor should shut off. The inside lights should change to RED and AMBER flashing. Rotate the selector switch to the **RESTRAINT OVERRIDE** position to silence the alarm (if equipped). The inside lights will change to AMBER

and GREEN. Push the **RELEASE** pushbutton to reset the lights. The inside light will switch to RED and the outside lights will switch to flashing GREEN.

6. Check hydraulic fluid in reservoir. If required, add hydraulic oil.

ACCEPTABLE HYDRAULIC OILS

A petroleum based, all weather hydraulic fluid with a viscosity of 15 CST @ 40°C (100°F), such as:

- Shell Tellus T 15
- Mobil Aero HFA (49011)
- Exxon Univis: HV13, N15, J13
- Texaco Aircraft Oil #1554
- U.S. Oil Co., Inc #ZFI-5606 (low temp.)

Fig. 13

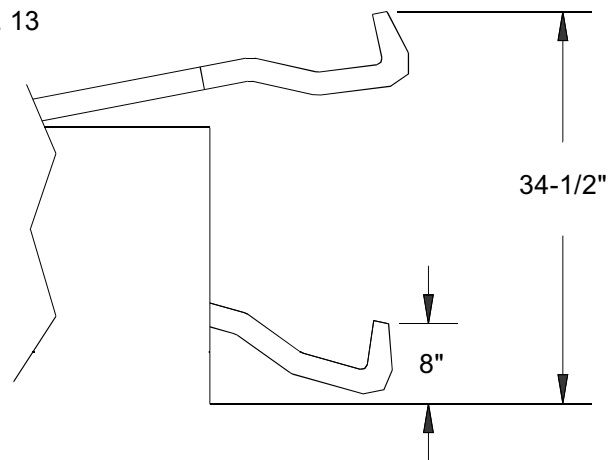
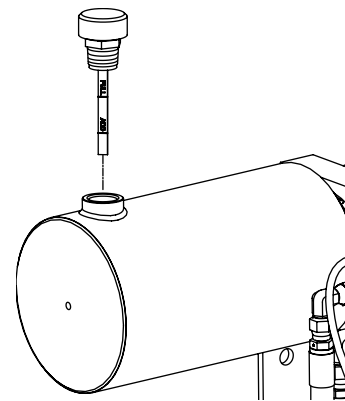

Fig. 14



* Use service mode to jog hook into position before checking oil level. (Ref. page 25)

START-UP AND TEST, continued

- Press **ENGAGE** pushbutton and measure lower and upper limits of the vertical operating range. The operating range should be 8" and 34.5" respectively. See Fig. 13. It is important to verify that the PRS1 signal remains on (PLC input 1) when the hook is lowered, especially as the hook is retracting.

⚠ WARNING

Before doing maintenance or service remove power at the fused disconnect. Disconnect must be properly tagged or locked out during maintenance or service of equipment. Failure to disconnect power may result in death or serious injury.

NOTE:

The upper and lower limits of the operating range given in manual are for the dock height and pit depth indicated on the pit drawing. These limits may not be attainable if variations in dock height and/or pit depth exist. Consult factory if this situation occurs.

Fig. 15

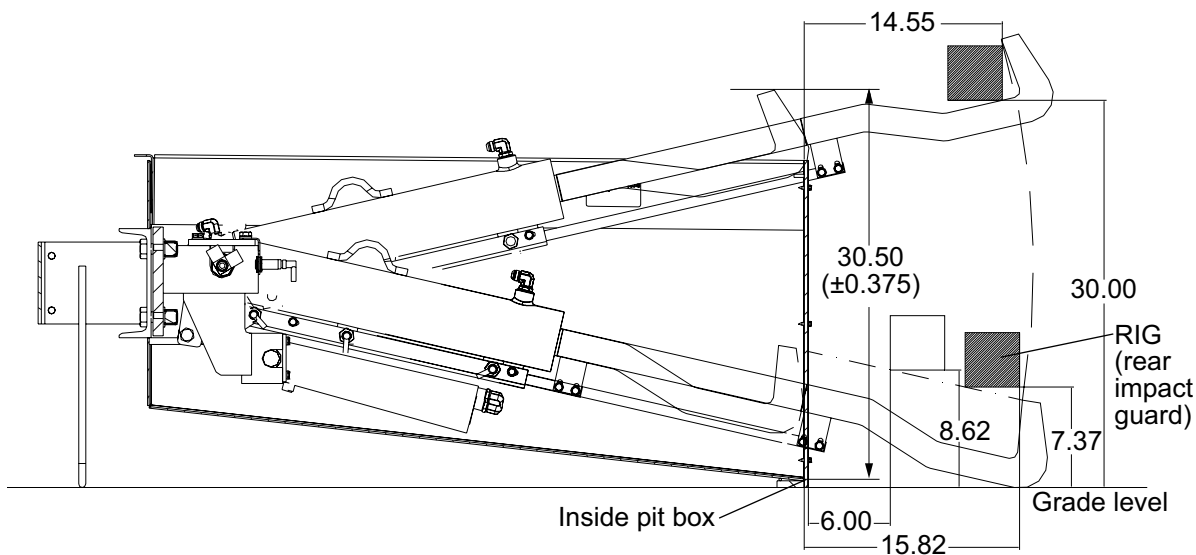

HOOK CYLINDER OPERATING RANGE

(Without Optional Cover)

NOTICE

Adjustment of the pressure relief above the maximum range could result in damage to the power unit or cylinders.

⚠ WARNING

Hook raises rapidly. Stand clear to the side of the hook when making measurements or adjustments.

Adjustment of the hook cylinder can be achieved through various means. The full working range is noted in Fig. 13. Proximity Switch 1 controls the lower travel limit of the hook. The Proximity Switch (PRS1) should be factory set at 3/32" away from the sensor block and ready for service. Use the following instructions to fine tune the hook position to fit your installation. See Fig. 17.

- Adjustment of the sensor block counterclockwise (CCW) lowers the hook.
- Adjusting of the sensor block clockwise (CW) Raises the hook.

Fig. 16

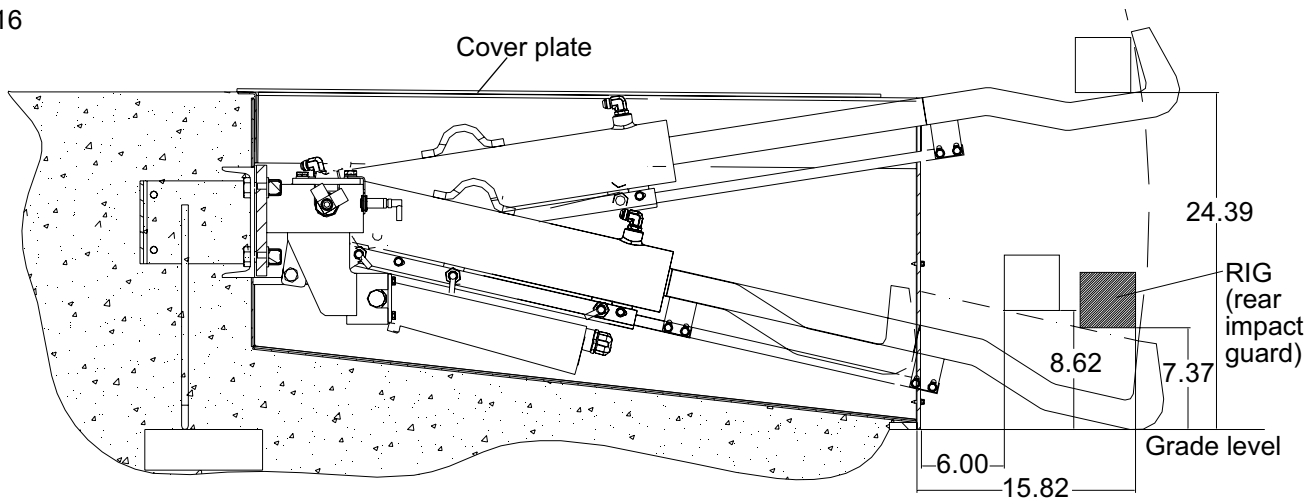

HOOK CYLINDER OPERATING RANGE

(With Optional Cover)

For applications requiring a pit cover the hook cylinder height will need to be adjusted to prevent hitting the cover. For shallow pits 26" and lower the cyclinder stop bolt will need to be replaced with the longer option. The hook assembly ships with a stock bolt 5/8-18UNF x 1-1/2. that can adjust hook height between 30-32". Use 5/8-18UNF x 1-3/4 bolt for 24-30" hook height range.

▲ WARNING

Hook raises rapidly. Stand clear to the side of the hook when making measurements or adjustments.

HOOK CYLINDER ADJUSTMENTS

Proximity Switch 1 controls the lower travel limit of the hook. The Proximity Switch (PRS1) should be factory set at 3/32" away from the sensor block and ready for service. Use the following instructions to fine tune the hook position to fit your installation. See Fig. 17.

1. Adjustment of the sensor block counterclockwise (CCW) lowers the hook.
2. Adjusting of the sensor block clockwise (CW) Raises the hook.

HOOK CYLINDER UPPER TRAVEL

The hook cylinder is fitted with a stop bolt that allows adjustment of the hook maximum height depending upon the application or with cover plates. See Fig. 16. The bolt is located between the upper cylinder trunnion mount blocks. See Fig. 18.

1. Loosen the jam nut on the bolt .
2. Adjusting the bolt in, increases the hook height.
3. Adjusting the bolt out, decreases the hook height.
4. Retighten jam nut.

Fig. 17

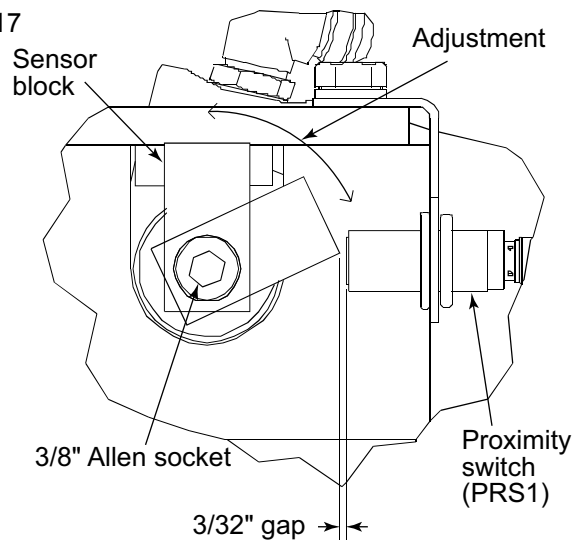
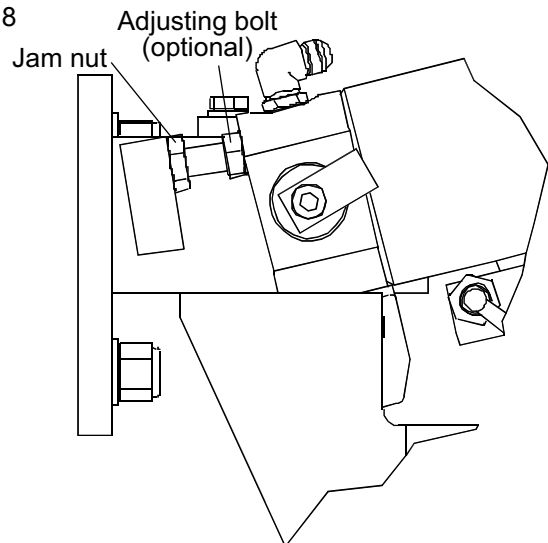

Fig. 18



START-UP AND TEST, continued

The following testing sequence are recommended for the initial check out of the Restraint operation. The cylinder and line should be purged and free of air.

HOOK CYLINDER TEST — NO VEHICLE



1. Apply power to the control panel.
2. With the restraint in stored position (UP).
3. Check the panel lights and exterior lights.

Control Panel Lights 	RED ONLY
Exterior Lights 	GREEN FLASHING

4. Push the **ENGAGE** button on the panel. The restraint will cycle through its motion. Lower-extend-raise and retract, finding no vehicle. The restraint will return to stored position and the alarm will sound (if equipped). The motor will shut off and the lights will show:

Control Panel Lights 	RED & AMBER FLASHING
Exterior Lights 	RED FLASHING

5. Rotate the selector switch to the **RESTRAINT OVERRIDE** to silence the alarm (if equipped). The lights will show:

Control Panel Lights 	GREEN & AMBER
Exterior Lights 	RED FLASHING

6. Push the **RELEASE** button to reset the lights to:

Control Panel Lights 	RED ONLY
Exterior Lights 	GREEN FLASHING

7. If the restraint or lights do not operate as stated above steps, refer to the troubleshooting guide starting on page 30.



Dock leveler can now be installed in pit per dock leveler's installation instructions. When placing dock leveler in pit, make sure all components of the vehicle restraint including hydraulic hoses and electrical cords do not interfere with dock leveler. If any welding is done in the pit, make sure to cover all components of vehicle restraint and disconnect power.

HOOK CYLINDER TEST — WITH VEHICLE

1. Position the vehicle with a RIG (rear impact guard) at dock.
2. Push **ENGAGE**. The restraint will cycle through its motion and latch the RIG. The motor should shut off and lights will show:

Control Panel Lights 	GREEN ONLY
Exterior Lights 	RED FLASHING

3. Push the **RELEASE** button and the restraint should return to stored position in the pit. The lights will show:

Control Panel Lights 	RED ONLY
Exterior Lights 	GREEN FLASHING

4. If the restraint or lights do not operate as stated above steps, refer to the troubleshooting guide starting on page 30.

NOTE:

If 120V lights are used, they will not flash.

OPERATING INSTRUCTIONS

⚠ WARNING

Before operating the vehicle restraint, read and follow the Safety Practices, Warnings, and Operation instructions contained in this manual. Use by untrained people could result in death or serious injury.

Do not use the Restraint if it looks broken or does not seem to work right. Tell your supervisor at once.

Keep hands and feet clear at all times. Stay clear of the vehicle restraint when it is moving.

*Do not load or unload any vehicle unless you make certain the vehicle restraint has securely hitched the vehicle's RIG (rear impact guard) and set the brakes. If the vehicle restraint does not hitch the vehicle's RIG for any reason, **BE CERTAIN TO MANUALLY CHOCK THE VEHICLE WHEELS BEFORE LOADING OR UNLOADING.***

Enter the vehicle only when the green signal light on the control box is on. You must check the green signal light each time that the vehicle is entered. If the green light goes off at any time during loading operations, immediately cease loading operations and check the vehicle restraint to insure that it is securely hitched.

If the power to the vehicle restraint is interrupted, immediately cease operations and check the unit. When power is reapplied, the restraint will usually not require operator input unless hook was moving when power was interrupted. If, when power is reapplied, inside light is flashing red and hook is not moving press engage or release as desired to reset restraint.

Vehicles leaving or moving when loading and unloading are in process, could result in death or serious injury.

Failure to follow these safety practices may result in death or serious injury.

NOTE:

To stop the restraint, simultaneously press the **ENGAGE** and **RELEASE** buttons to halt the restraint at any time during its travel. The restraint can then be restarted by pressing **ENGAGE** or **RELEASE** and will resume from the position it stopped.

TO CHOCK VEHICLE:

1. Press **ENGAGE** button.
2. Inside light will switch from steady RED to flashing RED.
3. Outside lights will switch to flashing RED.
4. When vehicle is properly hitched, the RED flashing inside light will switch to a GREEN steady light. Outside light will remain flashing RED.
5. If vehicle cannot be hitched, RED light will continue to flash with AMBER light and fault alarm (if equipped) will sound. If this occurs:
 - 5.1 Make certain vehicle brakes are set.
 - 5.2 Manually chock vehicle tires.
 - 5.3 Turn selector switch to **RESTRAINT OVERRIDE**.
 - 5.4 Inside lights will switch to AMBER and GREEN .
 - 5.5 Outside lights will remain flashing RED.
6. Vehicle may now be loaded/unloaded.
7. If a restraint malfunction occurs, the visual indication will be a **SOLID RED AND FLASHING AMBER LIGHT** on the control panel. When this happens, the AMBER light will be flashing a trouble code. This may happen for various reasons that require:
 - 7.1 To return restraint to the home position, Press and hold the **RELEASE** pushbutton selector switch.- This will activate the ARTH mode. Continue to hold until the restraint is stored. If the fault is cleared, the restraint can now be re-engaged.
 - 7.2 Press the **ENGAGE** pushbutton. If the cause of failure has not been cleared it may malfunction again. Repeat step 7.1 to return the hook to home position if necessary. Use manual wheel chocks until unit is repaired. Call for service.

OPERATING INSTRUCTIONS, continued

TO RELEASE VEHICLE:

1. Store dock leveler. (If present remove manual wheel chocks.)
2. Press **RELEASE** pushbutton.
3. Inside lights will switch to flashing RED.
4. Outside lights will continue to flash RED.
5. After hook is stored, inside lights switch to steady RED. Outside light will switch to flashing GREEN.
6. Vehicle may now pull out.

RESTRAINT OVERRIDE MODE (Lights Only)

In some instances it is desirable to put the restraint into **RESTRAINT OVERRIDE** mode without extending the hook out of the pan. An example would be if a lift gate vehicle is positioned at the dock.

TO CHOCK VEHICLE :

1. Make certain vehicle brakes are set.
2. Manually chock vehicle tires.
3. Turn selector switch to **RESTRAINT OVERRIDE**.
4. Inside lights will switch from steady RED to AMBER and GREEN. Outside lights will switch from flashing GREEN to flashing Red.
5. Vehicle may now be loaded/unloaded.

TO RELEASE VEHICLE (WHEN IN RESTRAINT OVERRIDE):

1. Store dock leveler. If present, remove manually placed chock.
2. Press **RELEASE** button.
3. Inside light will switch to RED.
4. Outside light will flash GREEN.
5. Vehicle may now pull out.

NOTE:

To stop the restraint, simultaneously press the **ENGAGE** and **RELEASE** buttons to halt the restraint at any time during its travel. The restraint can then be restarted by pressing **ENGAGE** or **RELEASE** and will resume from the position it stopped.

NOTE:

If 120V lights are used, they will not flash.

PLANNED MAINTENANCE

▲ DANGER

Before doing any electrical work (including changing bulbs), make certain the power is disconnected and properly tagged or locked off.

▲ WARNING

Do not service this product unless you have read and followed the Safety Practices, Warnings, and Operation instructions contained in this manual. Failure to follow these safety practices could result in death or serious injury.

After checking lights, be certain lights are returned to the proper display. If no vehicle is at the dock, or the vehicle is not chocked, the red inside light should be lit and green outside light should be flashing. If a vehicle is at the dock and RIG (rear impact guard) is hitched, the green inside light should be lit and the red outside light should be flashing.

DAILY

1. Operate the vehicle restraint to assure that it operates smoothly.
2. Check all lights and optional fault alarm (if equipped) to ensure they are in proper working order.
3. Inspect dock bumpers. Worn, torn, or missing bumpers must be replaced.

MONTHLY

1. Check fluid level on the reservoir. If required add hydraulic oil. See Fig. 14.
2. Check all operating, warning, and caution labels and signs to be sure they can be read. Replace them if required.
3. Check for loose, frayed and damaged wires or hydraulic leaks.

Fig. 19

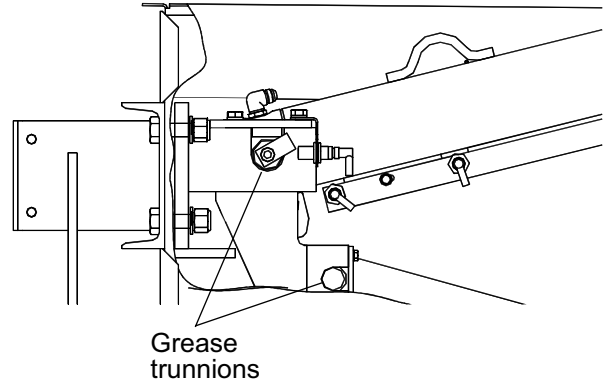

QUARTERLY

1. Grease hook and hold down cylinder trunnions. Remove trunnion caps and spray with a liberal amount of white lithium grease. See Fig. 19.
2. Check all operating, warning, and caution labels and signs to be sure they can be read. Replace them if required.
3. Inspect dock bumpers. Worn, torn, or missing bumpers must be replaced.

AS REQUIRED

1. Clean debris out of pan in pit.

SOLENOID AND PROXIMITY SWITCH LOCATIONS

SOLENOID 1: Lowers hook when energized.

SOLENOID 2: Extends hook when energized.

SOLENOID 3: Extends hook when energized.

PRS1: On when hook is fully lowered.

PRS2: On when hook is not fully extended.

PRS3: On when hook is not in working range (when hook does not hitch a rear impact guard).

PRS4: On when hook is fully retracted.

Fig. 20

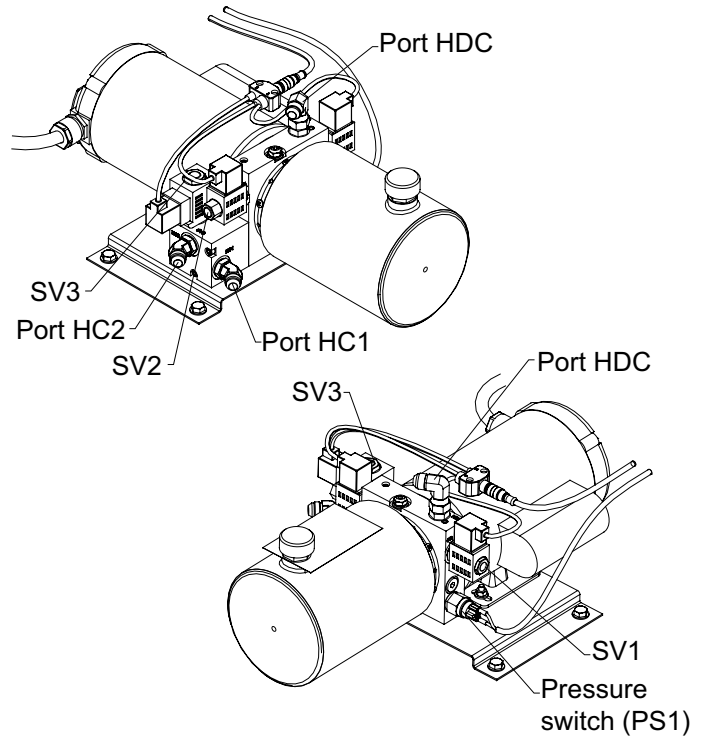
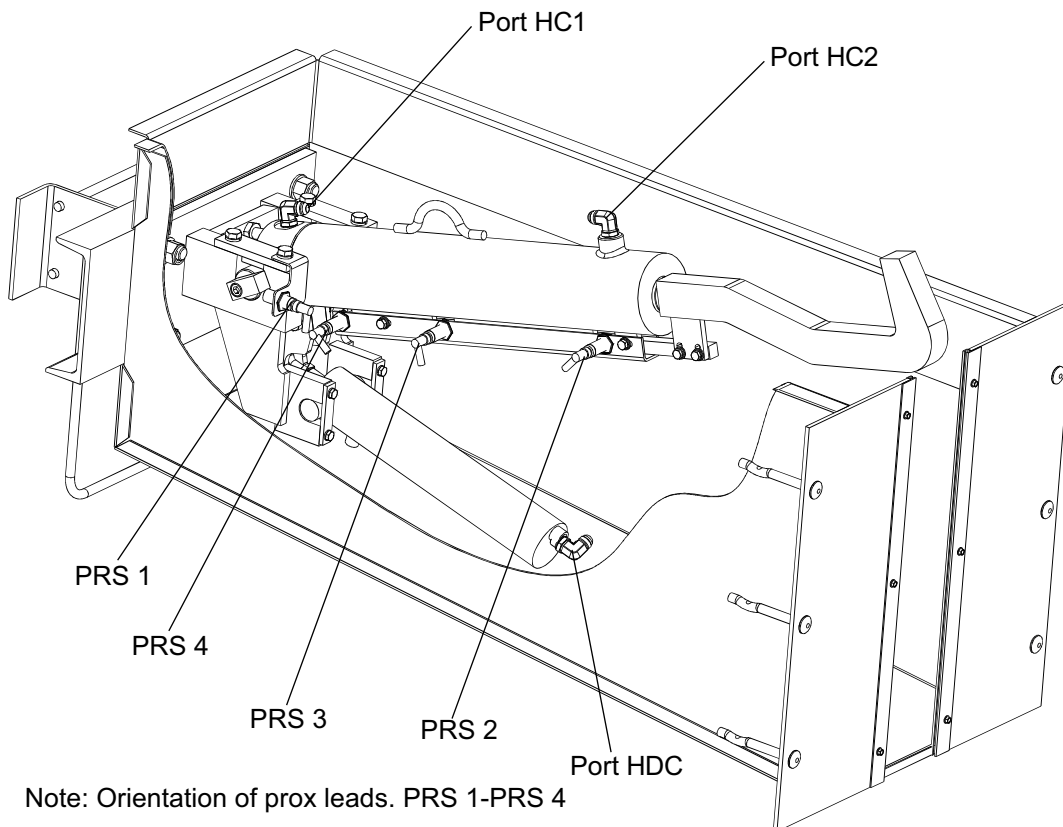

Fig. 21



Note: Orientation of prox leads. PRS 1-PRS 4

WIRING DIAGRAM

Fig. 22

120V/1PH/60HZ

NOTE: SUPPLY DISCONNECT MEANS CB/FU TO BE SUPPLIED BY OTHERS
 SUPPLY BCPD = CB/FU (SEE TABLE)
 PANEL FLA (SEE TABLE)
 SCCIR = 5KA

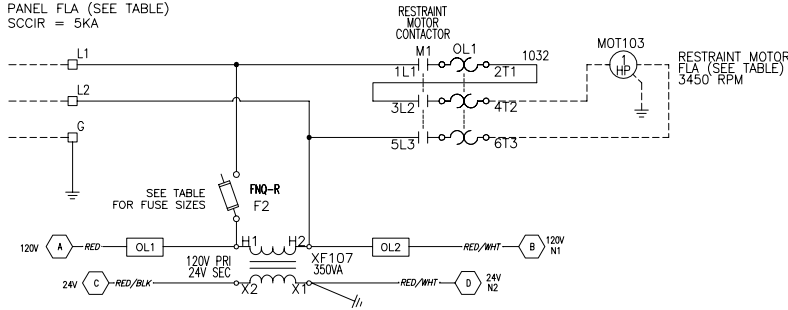

⚠ DANGER

Before doing any electrical work, make certain the power is disconnected and properly tagged or locked off. All electrical work must be done by a qualified technician and meet all applicable codes. If it is necessary to make troubleshooting checks inside the control box with the power on, USE EXTREME CAUTION. Do not place your fingers or uninsulated tools inside the control box. Touching wires or other parts inside the control box could result in electrical shock, death or serious injury.

NOTICE

Use caution when wiring outside lights. Be sure of the voltage rating of the light assembly you are installing.

Damage to outside lights caused by improper hook-up over voltage is NOT covered by warranty.

208-240V/1PH/60HZ

NOTE: SUPPLY DISCONNECT MEANS CB/FU TO BE SUPPLIED BY OTHERS
 SUPPLY BCPD = CB/FU (SEE TABLE)
 PANEL FLA (SEE TABLE)
 SCCIR = 5KA

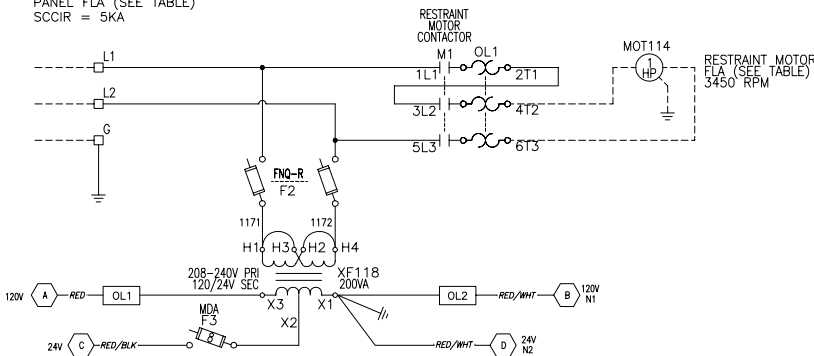

208-575V/3PH/60HZ

NOTE: SUPPLY DISCONNECT MEANS CB/FU TO BE SUPPLIED BY OTHERS
 SUPPLY BCPD = CB/FU (SEE TABLE)
 PANEL FLA (SEE TABLE)
 SCCIR = 5KA

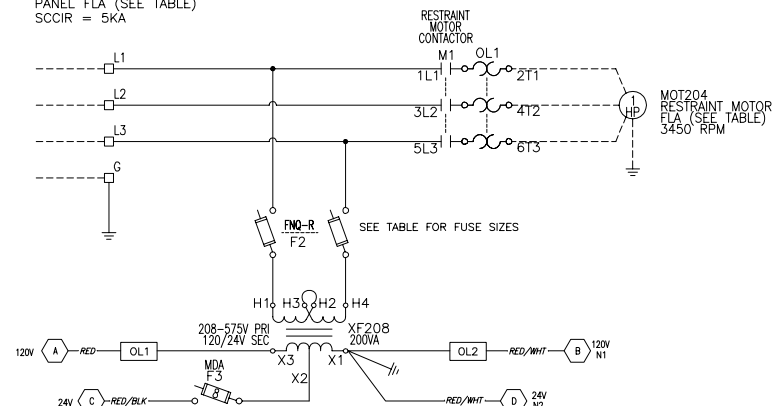

SINGLE PHASE PANEL REFERENCE						
VOLTAGE	BCPD	FUSE F2	MOTOR FLA	PANEL FLA	SERCO P/N	KELLEY P/N
120	25A	4A	14A	17.67A	6003330V1	6003331V1
208	15A	2.5A	7A	10.56A	6003330V2	6003331V2
240	12.5A	2A	6A	8.83A	6003330V3	6003331V3

USE CLASS CC TIME DELAY FUSES

THREE PHASE PANEL REFERENCE						
VOLTAGE	BCPD	FUSE F2	MOTOR FLA	PANEL FLA	SERCO P/N	KELLEY P/N
208	8A	2.5A	4A	5.75A	6003330V4	6003331V4
240	7A	2A	3.6A	5.03A	6003330V5	6003331V5
380	4A	1A	2A	2.52A	6003330V6	6003331V6
480	4A	1A	1.8A	2.52A	6003330V7	6003331V7
575	3A	0.8A	1.5A	2.25A	6003330V8	6003331V8

USE CLASS CC TIME DELAY FUSES

WIRING DIAGRAM, continued

Fig. 24

FIELD WIRING

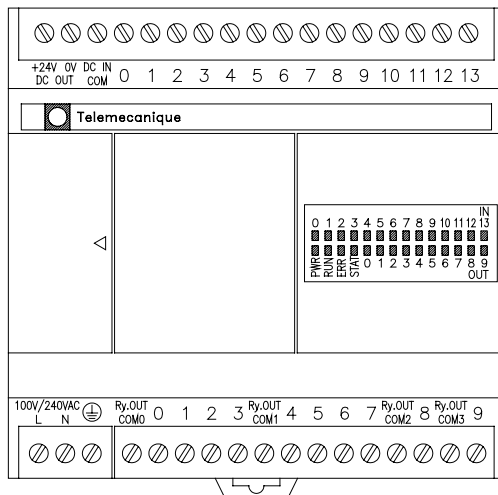
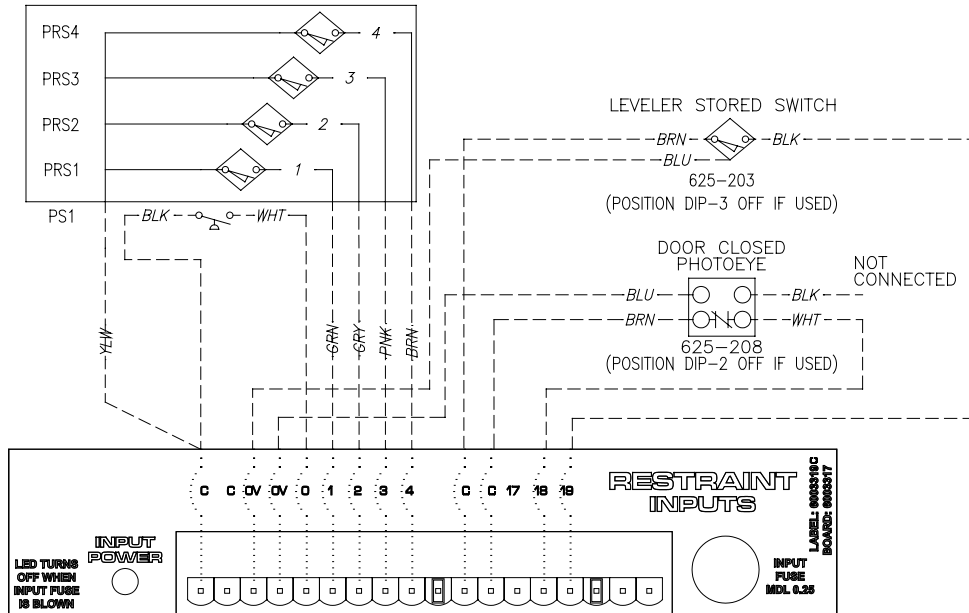

INPUT SIGNALS

0. PS1- Pressure ON
1. PRS1- ON Lowered
2. PRS2- OFF Extended
3. PRS3- OFF in Working Range
4. PRS4- OFF Retracted
5. SS1- Override
6. PB1- Raise
7. PB2- Lower
8. Spare
9. Door Closed
10. Leveler Stored
11. Spare
12. Spare
13. Spare

DEFAULT DIP SWITCH SETTINGS
LOCATED ON INPUT BOARD, RIGHT SIDE

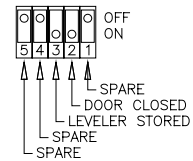

OUTPUT SIGNALS

0. Inside Green
1. Inside Amber
2. Inside Red
3. Outside Lights (red when off)
4. SV1
5. SV2
6. SV3
7. Motor contactor
8. Audible alarm
9. Interlock

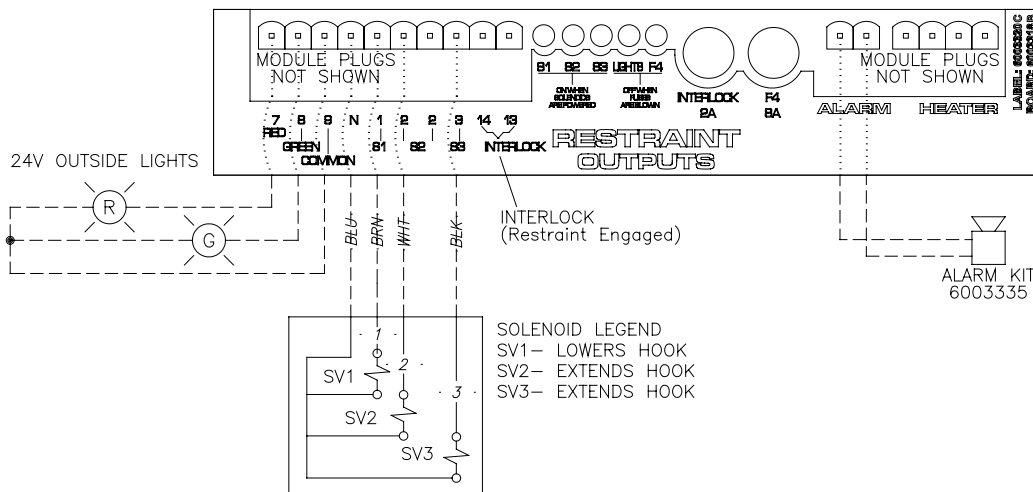

HYDRAULIC SCHEMATIC

Fig. 25

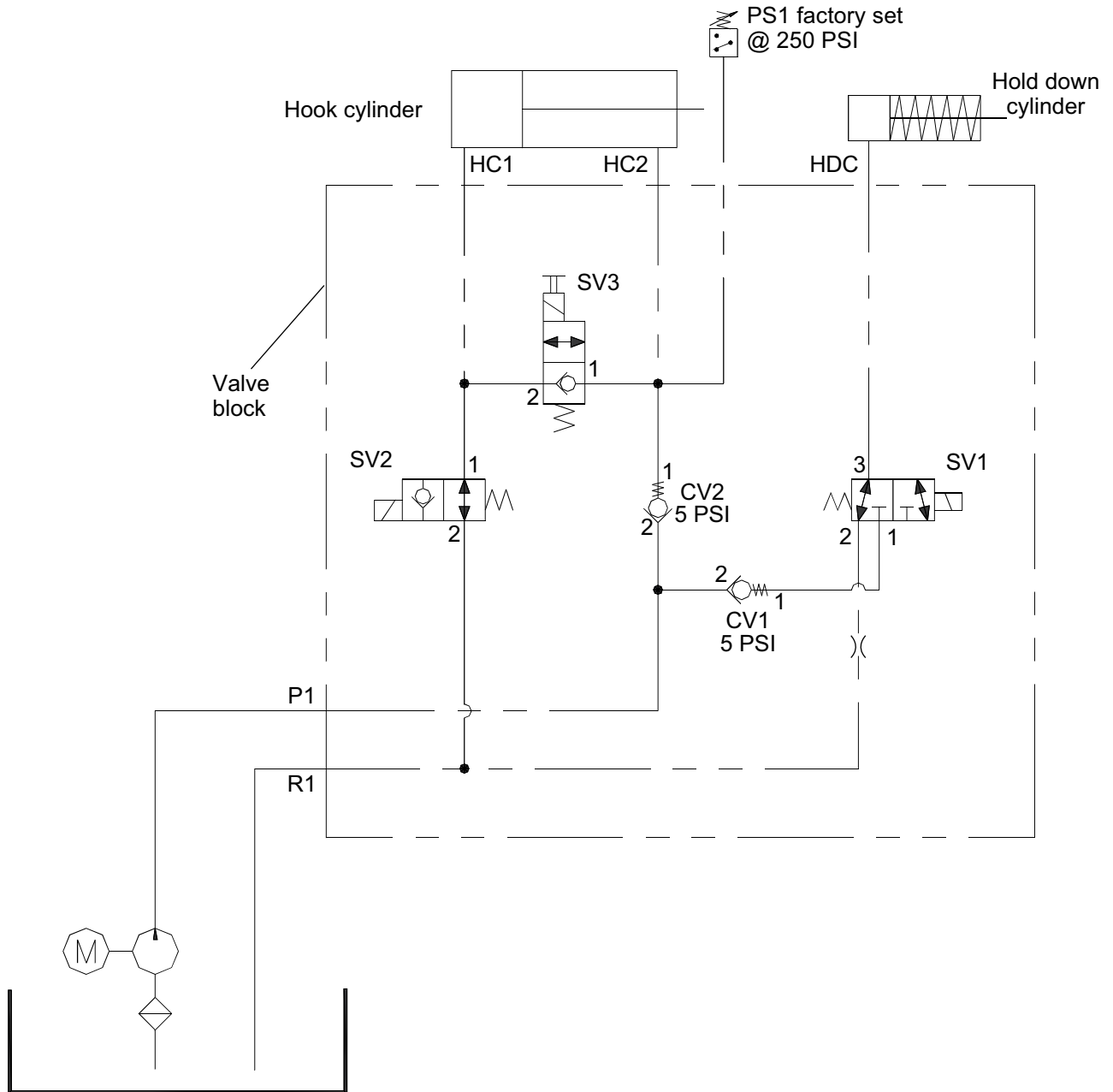

Hydraulic pump primary relief pressure set at 600 PSI.

PLC DIAGNOSTICS

⚠ DANGER

All electrical troubleshooting and repair must be done by a qualified technician and meet all applicable codes. The diagnostic and service modes are meant for installation and troubleshooting only.

⚠ WARNING

Do not service this product unless you have read and followed the Safety Practices, Warnings, and Operating Instructions in this manual. Failure to follow these safety practices could result in death or serious injury.

Keep hands and feet away from the restraint when in Diagnostics Mode. Operation may return as soon as the fault is cleared. Failure to keep clear could result in death or serious injury.

DIAGNOSTICS

This mode will be entered when a restraint malfunction occurs which is defined as a movement error or proximity switch failure. Dynamic monitoring will trap movement and intermittent restraint failures. The amber lamp will serve to report these failures by flashing a trouble code. Trouble code definitions are referenced in this manual on page 27.

AUTOMATIC RETURN TO HOME (ARTH)

This feature will return the restraint to its home position in the event of restraint malfunction. This mode can only be entered when a restraint malfunction has occurred. This will be the preferred recovery mode for the standard user because it does not require the user to visually monitor the restraint while operating. To initiate this mode, Press and hold the **RELEASE** pushbutton switch and continue to hold until the restraint is stored. Upon commencement, the unit will automatically begin a predetermined sequence and reset when it has reached the home position. The sequence can be terminated at any time by releasing the **RELEASE PUSHBUTTON** switch and can be reactivated as long as the restraint malfunction exists. This mode of operation does not acknowledge proximity switches or run timeouts. It runs along a predetermined path for a predetermined time to allow for proper storage of the restraint following a restraint malfunction.

SERVICE

This mode provides full manual control and a means to drive the restraint for a user determined amount of time in all supported directions. This mode is not subject to sequencing, proximity switch status or timeouts.

To activate **Service** mode: simultaneously press and hold **ENGAGE** and **RELEASE** pushbuttons for 5 seconds. All panel lamps will extinguish.

To clear **Service** mode and return to normal operation: simultaneously press and hold **ENGAGE** and **RELEASE** pushbuttons for 2 seconds. Panel lamps will resume the state held before **Service** mode activation or assume a new condition based on new input variables. Unit will exit **Service** mode automatically if no panel buttons are pressed in a 60 second time interval.

⚠ WARNING

When restraint leaves service mode it may move or raise rapidly. Stay clear of hook at all times.

While **Service** mode is active, press and hold the **ENGAGE** pushbutton to extend the hook. Likewise press and hold the **RELEASE** pushbutton to retract the hook. Rotate the **RESTRAINT OVERRIDE** switch to drive the hook down, then release and rotate again to release the hook. Each time the **RESTRAINT OVERRIDE** switch is sequenced the unit will switch between driving the hook down and releasing it to the raised position. These commands can be issued in any order and will maintain the ordered drive motion for as long as the switches are held active. This implementation is intended to smooth installation efforts.

PLC DIAGNOSTICS, continued

Position	Inside Light	Flash Rate
Home	Red	N/A
Moving	Red (flashing)	Medium
Stopped	Red (flashing)	Slow
Hitched	Green	N/A
RESTRAINT OVERRIDE	Green and Amber	N/A
Trailer Not Found	Red (flashing), Amber (flashing) and horn (pulsing)	Slow
Restraint Malfunction and ARTH mode	Red (on) and Amber (flashing)	Code
Service Mode	None	N/A

Outside light flashes GREEN only when all conditions are safe for the vehicle to arrive or depart, i.e. restraint and dock leveler stored with no alarms present. It flashes RED by default.

DIAGNOSTICS

If a restraint malfunction has occurred:

- Inside AMBER lamp is flashing a trouble code.
- Engage and Release functions are disabled.
- Inside RED lamp is on.

To identify the specific problem, count the flashes of the Amber lamp and compare the number to the table below. The count sequence will be repeated until the restraint malfunction is cleared. A two second pause between flash sequences is employed.

A single, slow repeated, red flash is not an error. The restraint power has been stopped either by using intervention or power loss. Press **ENGAGE** or **RELEASE** to continue.

Trouble Code	Trouble Definition
2	Lower/Raise timeout: Failure to detect PRS1 on while fully lowered or off when raised.
3	Extend timeout: Failure to detect PRS2 off while fully extended
4	Retract to RIG timeout: Failure to detect PS1 or PRS3 on while seeking ICC
5	Full retract timeout: Failure to detect PRS4 on while retracting to home position
6	Reaction timeout: Slow cylinder response or proximity switch failure (PRS2/3/4)
7	Hook is not stored or at least one of the following proximity switches has failed (PRS2/3/4)
8	PS1 failure
9	PS1 on while retracting to home position or fully retracted while PRS4 is off (possible obstruction present)
10	Static proximity switch failure (PRS2/3/4)
11	Master motor run timeout: Motor has exceeded its maximum allowed run time

PLC DIAGNOSTICS, continued

CONTROL PANEL — LED DISPLAY

The vehicle restraint is controlled by a solid state Programmable Logic Controller (PLC) which reads input signals from the pushbuttons and proximity sensors, and closes the appropriate output relays to the motor and to the warning lights.

Input Signals

- 0 - Engage pressure switch (On when pressure indicated), PS1
- 1 - Lowered proximity switch (On when fully lowered), PRS1
- 2 - Extended proximity switch (Off when fully extended), PRS2
- 3 - Working range proximity switch (Off when in working range), PRS3
- 4 - Retracted proximity switch (On when fully retracted), PRS4
- 5 - Restraint Override (momentarily off when selected)
- 6 - Engage pushbutton
- 7 - Release pushbutton
- 8 - Optional Trailer Presence Sensor* (DIP switch position 4)
- 9 - Optional Door Closed switch (DIP switch position 2)
- 10 - Optional Leveler stored switch (DIP switch position 3)
- 11 - Spare Input
- 12 - Spare Input
- 13 - Spare Input

Output Signals

- 0 - Inside Red light
- 1 - Inside Amber light
- 2 - Inside Green light
- 3 - Outside light relay (red when off)
- 4 - Solenoid valve 1 (Lowers hook when on)
- 5 - Solenoid valve 2 (Extends or lowers hook when on)
- 6 - Solenoid valve 3 (Extends or raises hook when on)
- 7 - Motor
- 8 - Audible Alarm (Optional)
- 9 - Leveler Interlock

*Restraint Panels Only. Master panels may be in a different location.

0	1	2	3	4	5	6	7	8	9	10	11	12	13	
														INPUTS
														OUTPUTS
PWR	RUN	ERR	STAT	0	1	2	3	4	5	6	7	8	9	

TWIDO PLC DISPLAY

PLC DIAGNOSTICS, continued

The chart below shows all of the valid conditions for the PLC unit in normal operation.

Home
Hook fully retracted
(stored)

0	1	2	3	4	5	6	7	8	9	10	11	12	13
			●	●	●	●				●	●		
●	●			●				●					
PWR	RUN	ERR	STAT	0	1	2	3	4	5	6	7	8	9
				INPUTS									
				OUTPUTS									

Step 6
Hook extending
(releasing)

0	1	2	3	4	5	6	7	8	9	10	11	12	13
●		E			●		●			●	●		
●	●			F					●	●	●		
PWR	RUN	ERR	STAT	0	1	2	3	4	5	6	7	8	9
				INPUTS									
				OUTPUTS									

Step 1
Hook lowering

0	1	2	3	4	5	6	7	8	9	10	11	12	13
●			●	●	●	●				●	●		
●	●			F				●	●	●			
PWR	RUN	ERR	STAT	0	1	2	3	4	5	6	7	8	9
				INPUTS									
				OUTPUTS									

Step 7
Hook lowering

0	1	2	3	4	5	6	7	8	9	10	11	12	13
●	E				●					●	●		
●	●			F				●	●	●			
PWR	RUN	ERR	STAT	0	1	2	3	4	5	6	7	8	9
				INPUTS									
				OUTPUTS									

Step 2
Hook extending

0	1	2	3	4	5	6	7	8	9	10	11	12	13
●		E	E	E	●					●	●		
●	●			F				●	●	●			
PWR	RUN	ERR	STAT	0	1	2	3	4	5	6	7	8	9
				INPUTS									
				OUTPUTS									

Step 8
Hook retracting

0	1	2	3	4	5	6	7	8	9	10	11	12	13
	●	E	E	E	●					●	●		
●	●			F				●		●			
PWR	RUN	ERR	STAT	0	1	2	3	4	5	6	7	8	9
				INPUTS									
				OUTPUTS									

Step 3
Hook raising

0	1	2	3	4	5	6	7	8	9	10	11	12	13
					●					●	●		
●	●			F					●	●			
PWR	RUN	ERR	STAT	0	1	2	3	4	5	6	7	8	9
				INPUTS									
				OUTPUTS									

Unsuccessful hitch
(TNF)

0	1	2	3	4	5	6	7	8	9	10	11	12	13
		●	●	●	●					●	●		
●	●			F	F							F	
PWR	RUN	ERR	STAT	0	1	2	3	4	5	6	7	8	9
				INPUTS									
				OUTPUTS									

Step 4
Hook engaging
(Seeking RIG)

0	1	2	3	4	5	6	7	8	9	10	11	12	13
		E			●					●	●		
●	●			F						●			
PWR	RUN	ERR	STAT	0	1	2	3	4	5	6	7	8	9
				INPUTS									
				OUTPUTS									

Restraint Override
selected

0	1	2	3	4	5	6	7	8	9	10	11	12	13
	E	E	E	E						●	●		
●	●				●	●							●
PWR	RUN	ERR	STAT	0	1	2	3	4	5	6	7	8	9
				INPUTS									
				OUTPUTS									

Step 5
Hook fully engaged
(RIG contacted)

0	1	2	3	4	5	6	7	8	9	10	11	12	13
E		●			●					●	●		
●	●				●								●
PWR	RUN	ERR	STAT	0	1	2	3	4	5	6	7	8	9
				INPUTS									
				OUTPUTS									

● On

F Flashing

E LED on or off (either condition may be present during sequence)

TROUBLESHOOTING

Use the Troubleshooting Guide if the vehicle restraint fails to perform properly. Find the condition that most closely matches your situation, and make the recommended adjustments.

▲ DANGER

Before doing maintenance or service remove power at the fused disconnect. Disconnect must be properly locked out during maintenance or service of equipment. Failure to disconnect power may result in death or serious injury.

Some of the following steps will be taken with the power on and the control box open. Only qualified electrical personnel should access the control box while under power.

▲ WARNING

Do not service this product unless you have read and followed the Safety Practices, Warnings, and Operation instructions contained in this manual. Failure to follow these safety practices could result in death or serious injury.

Hook raises rapidly. Stand clear to the side of the hook when making adjustments.

PROBLEM	POSSIBLE CAUSE	SOLUTION
1. Lights on Control Panel or outside lights not working.	a) Disconnect Switch OFF b) Mis-wired power to control panel or blown fuse c) Bulb/LEDs Burned out.	a) Check that the fused disconnect switch is on. b) Check all transformers and fuses for power. See wiring diagram on page 21. c) Replace bulb or LED board.
2. Unit not operational - Control Panel receiving power.	a) The PLC run and power LED's should be on and the ERR should be off. b) If RUN LED is flashing a programming error has occurred or the program has been lost or damaged.	a) Check for 120V on L&N Terminals of PLC. b) PLC needs new Program.

TROUBLESHOOTING, continued

PROBLEM	POSSIBLE CAUSE	SOLUTION
3. Restraint Operates Slowly.	<ul style="list-style-type: none"> a) Contaminated, wrong type or low hydraulic fluid. b) Damaged or blocked hydraulic hose. c) Blocked valve. 	<ul style="list-style-type: none"> a) Add fluid to reservoir. Do not overfill. Change fluid as required. b) Remove blockage in hose. Replace as required. c) Remove blockage in valve or replace.
4. Restraint does not fully extend.	<ul style="list-style-type: none"> a) Incorrectly wired solenoid valve. b) Low hydraulic fluid. c) Low system pressure. d) Incorrectly wired or adjusted proximity switch. 	<ul style="list-style-type: none"> a) Check wiring to solenoid valve. b) Add fluid as required. c) Check wiring to pressure switch. d) Check wiring to proximity switch.
5. Restraint lowers, fully extends but does not raise.	<ul style="list-style-type: none"> a) Solenoid "1" spool stuck ON. b) PRS2 not properly adjusted or not working. 	<ul style="list-style-type: none"> a) Remove "SV1" valve from manifold block. Check for contamination or blockage. Replace if damaged. b) Check wiring to PRS2. (PRS2 should be off when hook is fully extended.)
6. Restraint extends from stored position without fully lowering.	<ul style="list-style-type: none"> a) PRS1 not adjusted properly. 	<ul style="list-style-type: none"> a) Adjust PRS1 and target (See Fig. 16, page 14)
7. When Engaging, hook lowers and extends, but will not retract.	<ul style="list-style-type: none"> a) Solenoid valves SV2, SV3 stuck or incorrectly wired. 	<ul style="list-style-type: none"> a) Inspect SV1, SV2. Check wiring to valves.
8. Restraint extends from stored position without lowering.	<ul style="list-style-type: none"> a) PRS1 out of adjustment. b) SV1 Stuck OFF or not receiving signal or energizing. 	<ul style="list-style-type: none"> a) Adjust PRS1 as per Fig. 16, page 14. b) Check SV1 Operation, check valve for contamination.
9. Restraint does not lower from stored position.	<ul style="list-style-type: none"> a) SV1 stuck OFF. b) SV1 not energizing. c) SV1 receiving signal - not energizing. d) Obstruction in pit. 	<ul style="list-style-type: none"> a-c) Check wiring to proximity sensors, solenoid valves, and pressure switch. b) SV1 not receiving signal. c) Possible bad coil or valve. d) Check pit and clear pit of debris.

TROUBLESHOOTING, continued

PROBLEM	POSSIBLE CAUSE	SOLUTION
10. Restraint partially lowers from stored position.	a) Obstruction preventing motion. b) System pressure too low.	a) Check cylinder for motion. b) Increase pressure per procedure on page 33.
11. Restraint fully lowers from stored position but does not extend.	a) PS1 out of adjustment.	a) Adjust PRS1 as per Fig. 16, page 15.
12. Restraint does not tightly engage RIG (gap between hook and RIG)	a) PRS1 set to low.	a) Adjust PS1 as per Fig. 16, page 33.
13. Restraint extends from RIG and lowers but does not retract.	a) SV2 or SV3 stuck ON. b) PRS1 out of adjustment.	a) Check valves for obstruction. b) Adjust PRS1.
14. Pump does not shut off after engaging.	a) PS1 set too high.	a) Adjust PS1 as per page 33.
15. Motor shuts off prematurely.	a) PLC output to motor contactor is OFF. b) Motor overload relay is tripping.	a) Refer to PLC diagnostics on page 25. b) Set overload relay to full load current as shown on motor nameplate.
16. Hook lifts too fast. Engagement with trailer RIG too hard.	a) Flow restrictor behind HDC port in manifold too loose.	a) Adjust fitting at HDC port in manifold in. Gap should be approx 1/16-1/8". Adjust until hook cylinder travel is about 1-2 sec rise time.
17. Hook does not lift.	a) Flow restrictor behind HDC port in manifold too loose.	a) Remove fitting clean port and flow restrictor. Note orientation - groove must face HDC fitting.

TROUBLESHOOTING, continued

NOTE:

The following steps require a hydraulic pressure gage. Obtain a 2-1/2" liquid filled pressure gage with a 1000 PSI full scale reading. Using suitable adapters, attach a 1/4" to 3/8" ID hydraulic hose approx. 3 feet long to the gage. Terminate the other end of the hose with a female #8 JIC swivel nut fitting. Connect the center leg of a #8 JIC "run tee" to the hose. The top of the tee has a female JIC swivel nut directly opposite a male JIC. With this gage setup, you should remove the hose fitting from manifold port HC2, and reconnect using the tee. The gage is now "teed" into the line, without disturbing the hydraulic circuit.

PROCEDURE FOR SETTING THE SLP/HH3000 PRESSURE SWITCH AND PRIMARY RELIEF VALVE

Tip: Buy a #8 JIC male plug and a female cap #8 JIC fitting. Use these to seal up and protect the gage tee when not in use.

Switch on control panel.

1. Verify the reservoir is filled to the correct level with ISO15 hydraulic fluid.
2. Unscrew threaded cap from hydraulic power unit primary relief pressure valve. Do not lose the cap.
3. Turn relief pressure adjusting screw counterclockwise (CCW) approx. 3-turns. NOTE: Be careful not to completely unscrew the adjustment! This adjusting screw compresses a spring. STOP turning CCW as soon as the spring resistance feels loose, with threads still engaged.
4. Loosen prox. sensor PRS1 target, and rotate it all the way CCW (up and rearward). PRS1 must NOT turn on while making these adjustments.
5. With Selector Switch in the NORMAL OPERATION position, press the **ENGAGE** pushbutton. While the motor is running, turn the relief pressure adjusting screw CLOCKWISE (CW) until the gage reads 160-170 PSI.
6. With the motor running, and the gage indicating 160-170 PSI, adjust the pressure switch, PS1, until the PLC pressure switch input light just turns ON. NOTE: CCW rotation will make PS1 turn on at a lower pressure.
7. Press the **ENGAGE** pushbutton, and slowly turn the primary relief valve CLOCKWISE, just enough to allow the hold down cylinder to swing all the way down. When the hook cylinder is fully lowered, slowly turn the relief valve CW until the gage reads 600 PSI. Replace relief valve cap.

8. Press **ENGAGE**, and when the hook cylinder swings all the way down, carefully adjust PRS1 target until the sensor turns on (sensor will light up). Be careful, as the hook will immediately begin to extend when PRS1 turns on. NOTE: PRS1 must turn on without hesitation as the hook cylinder swings all the way down.

PROCEDURE FOR SOLENOID VALVE REPAIR OR REPLACEMENT

The hydraulic valves used in the SLP/HH are mechanical components subject to blockage if contamination is allowed into the hydraulic system. The following steps define removal, inspection and installation of the valves.

REMOVAL

1. Remove coil retaining nut.
2. Remove coil by sliding off valve body.
3. Remove valve using a box wrench. Do not use an adjustable wrench or pliers - damage to valve will occur.

INSPECTION

1. Carefully wipe off valve with clean rag (do not dry o-ring on spool). WD-40® or similar spray can be used to clean the valve.
2. Check valve block for contaminants. Clean using air pressure or WD-40® or similar spray.

NOTICE

Do not stick sharp objects into valve or valve body. Damage to critical seal surfaces could occur.

INSTALLATION

1. Lightly lubricate with oil, replace valve in block and tighten to 30 ft lbs.
2. Install coil and nut, tighten to 3 ft lbs.

NOTICE

Overtightening nut may damage the coil.

3. Test valve by operating coil. Replace valve if problem persists and after all other troubleshooting steps have been performed.

PARTS LIST — PAN

⚠ WARNING

To ensure proper function, durability and safety of the product, only replacement parts that do not interfere with the safe, normal operation of the product must be used. Incorporation of replacement parts or modifications that weaken the structural integrity of the product, or in any way alter the product from its normal working condition at the time of purchase from 4Front Engineered Solutions, Inc. may result in product malfunction, breakdown, premature wear, death or serious injury.

Fig. 26

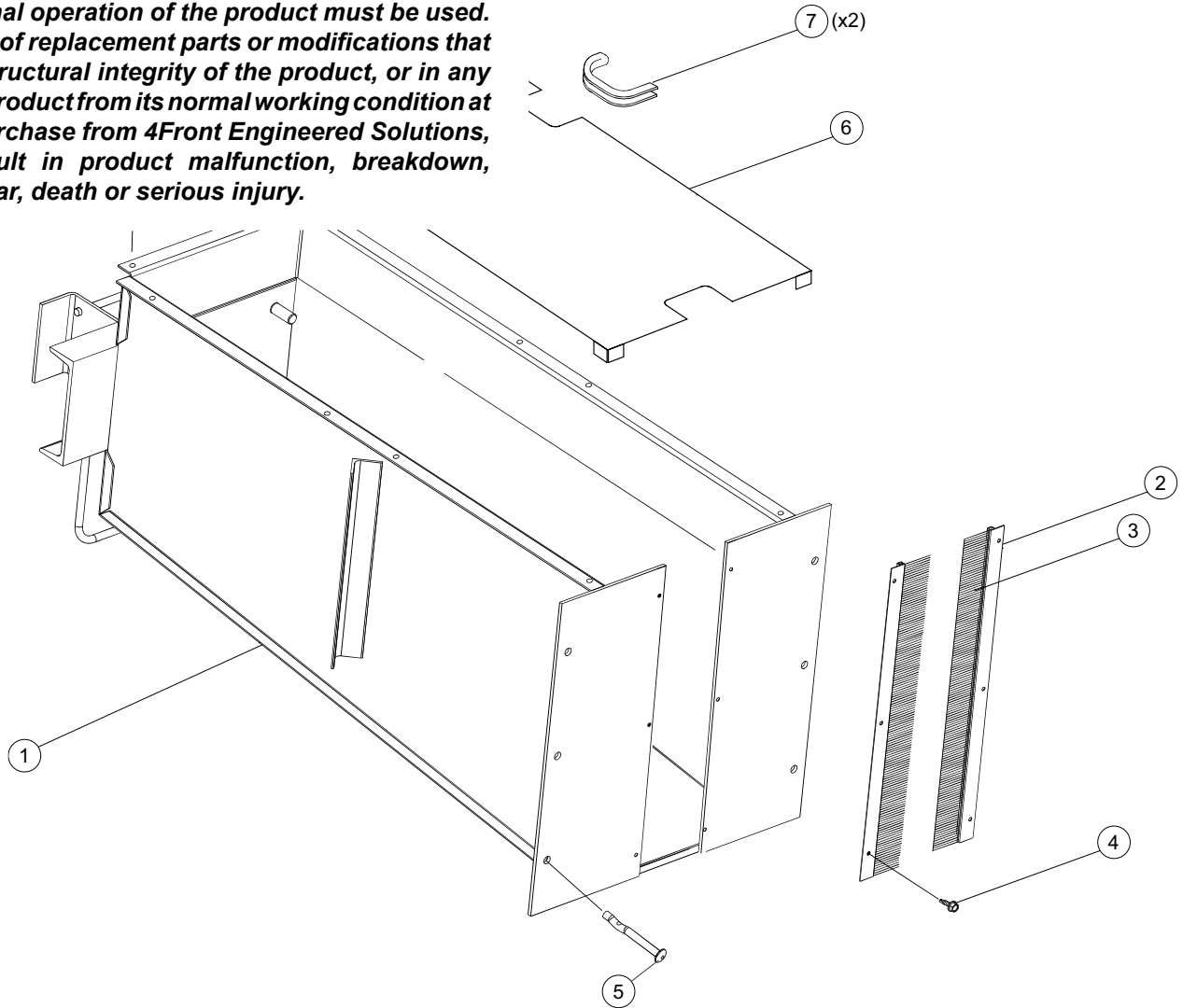

Item	Quantity	Description	Part Number
1	1	SLP PIT BOX TELESCOPING ASSY 24"	6001823
	1	SLP PIT BOX TELESCOPING ASSY 26"	6001825
	1	SLP PIT BOX TELESCOPING ASSY 28"	6001827
	1	SLP PIT BOX TELESCOPING ASSY 30"	6001829
2	2	EXTRUSION, WEATHER SEAL	6001798
3	2	BRUSH, WEATHER SEAL	6001799
4	6	FASTENER, STS #12-14 TEKS	215702
5	6	SPIKE ANCHOR	6001910
6	1	PIT COVER (OPTIONAL)	6004767
7	4	EDGE STRIP, COVER	6001984

PARTS LIST

Fig. 27

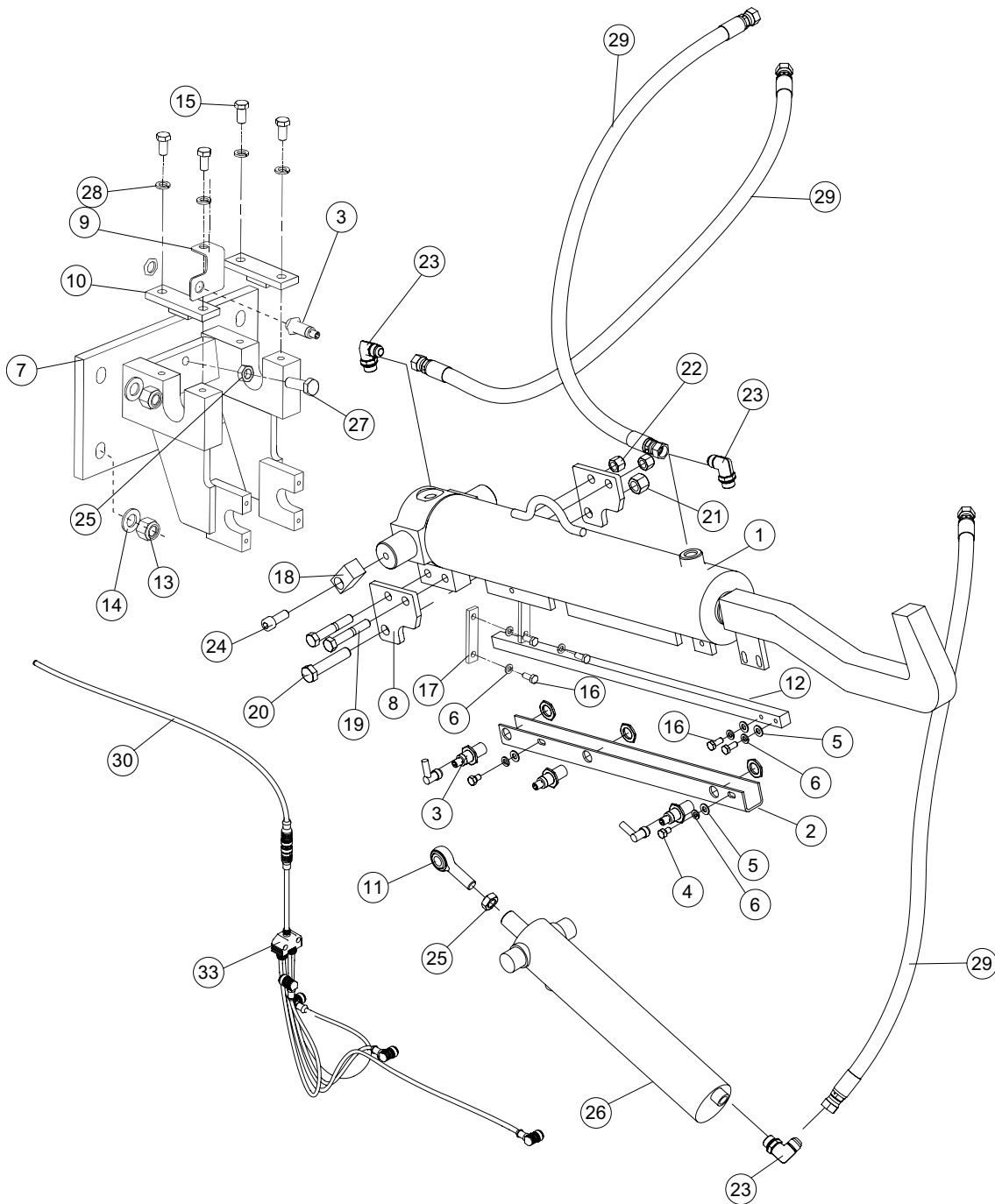

PARTS LIST, continued

Item	Quantity	Description	Part Number
1	1	HOOK CYLINDER ASSY	6001548
2	1	TRACK, GUIDE	156-134
3	4	PROXIMITY SWITCH	6001861
4	2	BOLT, HEX HD, 5/16-18 X 1/2, ZP	000804
5	2	PW 5/16 BOLT SIZE- 3/8 HOLE	234-091
6	6	LW, 5/16 MED ZINC PLD BULK	234-291
7	1	TRUNNION	6001767
8	2	TILT BRACKET	6001781
9	1	PROXIMITY SWITCH BRACKET	6001816
10	2	KEEPER, TRUNNION HOOK CYLINDER	713-625
11	1	ROD, END	156-157
12	1	ROD, GUIDE	156-133
13	4	LN, 3/4-10, NYLON, ZP	214-558
14	4	PW 3/4 BOLT SIZE, 13/16 HOLE	234-141
15	4	BOLT, HEX HD, 1/2-13 X 1, ZP	000102
16	6	BOLT, HEX HD, 5/16-18 X 3/4, ZP	212052
17	2	KEEPER, HOLD DOWN	156131
18	1	PROX SENSOR BLOCK	6001782
19	2	BOLT, HEX HD, 1/2-13 X 3, UTIL, ZP	000275
20	1	BOLT, HEX HD, 5/8-11 X 3, ZP	000466
21	1	NUT, LOCK, 5/8-11	000028
22	2	NUT, LOCK, 1/2-13 ZP	000035
23	3	ELBOW, 90 DEG	206-221
24	1	SCREW, SCKT HD CAP, 1/2-13X1 1/4, ZP	6001821
25	2	NUT, JAM, 5/8-18 UNF, ZP (OPTIONAL)	131-550
26	1	HOLD DOWN CYLINDER	713-695
27	1	HHMB, 5/8-18 UNF X 1 LG, ZP (OPTIONAL 1-3/4 LG WITH COVER)	6001820
28	4	LW, 1/2, MED ZINC PLD BULK	000066
29	3	HOSE ASSY, 1/2 ID X 13/16 OD X 60LG (6' AND 8' LEVELER) HOSE ASSY, 1/2 ID X 13/16 OD X 88LG (10' LEVELER)	6001874 6006897
30	1	HOME RUN CABLE, 8 LEAD, QD, 10M	6008848
31	1	SERIAL TAG (NOT SHOWN)	6009761
32	1	OWNER'S MANUAL (NOT SHOWN)	6011489
33	1	CORD SET, QD, SLP, PRS1-PRS4	6010344

PARTS LIST — POWER UNIT, continued

Fig. 28

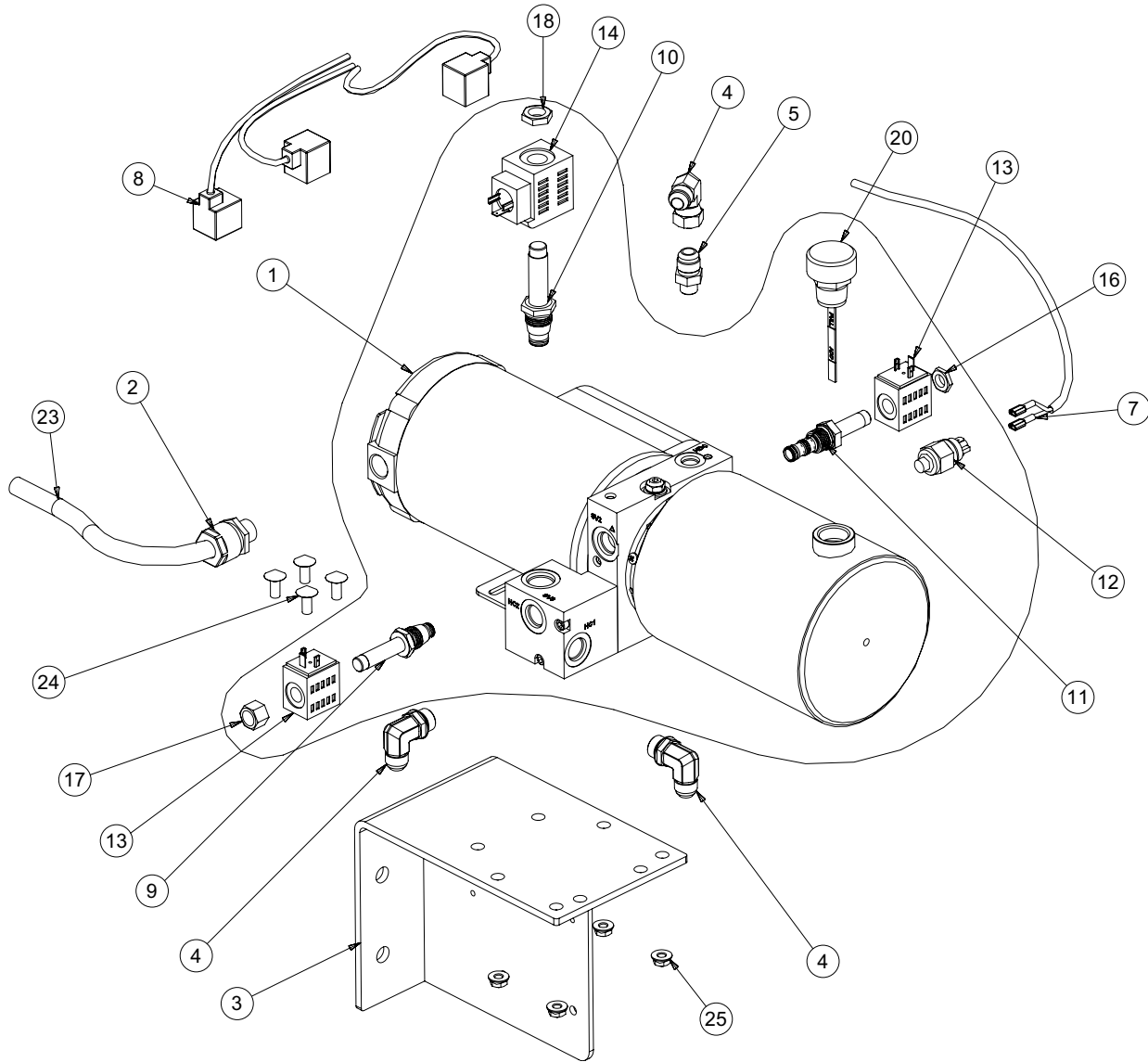

PARTS LIST — POWER UNIT, continued

Item	Quantity	Description	Part Number
1	1	HYDRAULIC POWER UNIT, SLP/HH, 120-220V/1/50-60, BHGR HYDRAULIC POWER UNIT, SLP/HH, 208-480V/3/50-60, BHGR HYDRAULIC POWER UNIT, SLP/HH, 575V/3/50-60, BHGR HYDRAULIC POWER UNIT, SLP/HH, 24VDC0, BHGR	6012583 6012584 6012584 6012596
2	1	CABLE GRIP, 1/2" HUB, 5/8 CABLE	533424
3	1	BRACKET WDMT PUMP, WALL MNT, -BHGR	6012018
4	2	FTG, 90° ELBOW, 8-JIC-F SWIVEL X 8-JIC-M, STL, (8 V5OX-S)	313586
5	1	FTG, STR THD CONN, 8-JIC-M X 6-SAE ORB-M, STL, (6006640
6	1	FTG, 90° SWIVEL NUT ELBOW, 8-JIC-F SWIVEL X 8-JIC-M, STL, (8-C6XS)	6011446
7	1	CABLE ASSY, PS1, SLP/HH, 10M	6011461
8	3	MOLDED SOLENOID CORD, DIN 43650 PLUG, 2M	6008052
9	1	SOLENOID VALVE, NO, POPPET, 2W-2P LOAD HOLDING, SAE-8, (SV2)	6011480
10	1	SOLENOID VALVE, NC, PILOT OPERATED POPPET, SAE 10, 2W-2P, LOAD HOLDING, (SV3)	6011481
11	1	VALVE, 3W-2P, DIRECTION CONTROL SPOOL, SAE-8, (SV1)	6011478
12	1	PRESSURE SWITCH-ADJ, 250 PSI, 2 SPADE,	6011483
13	2	COIL, 1/2 SOLENOID, 24VAC DTL COIL, 1/2 SOLENOID, 24VDC DTL	6011937 6011939
14	1	COIL, 5/8 SOLENOID, 24 VAC, DTL COIL, 5/8 SOLENOID, 24 VDC, DTL	6011945 6012125
15	4	SLEEVE ANCHOR, 1/2" X 3-3/4" LG.	131260
16	1	RETAINING NUT, 1/2" SOLENOID	6011725
17	1	LONG RETAINER NUT, 1/2" SOLENOID	6011726
18	1	RETAINER NUT, 5/8" SOLENOID,	6011727
19	1	RESERVOIR KIT, .7 GAL, STEEL, (STEEL TANK, FILTER, SEAL, MNTG SCREWS)	6012632
20	1	BREATHER CAP W/ DIPSTICK	6012637
21	1	LABEL, SINGLE PHASE LABEL, TRIPLE PHASE	921026 921027
22	1	LABEL, 120 VOLT LABEL, 208 VOLT LABEL, 220 VOLT LABEL, 480 VOLT LABEL, 575 VOLT LABEL, 24 VOLT DC	921051 921050 921052 921053 921054 6010601
23	1	POWER CABLE, SO 14/4 X 42" LG (1 PH MTR) POWER CABLE, SO 14/3 X 42" LG (3 PH MTR)	172607 172603
24	4	5/16-18UNC X 1" LG RD HD CARG BOLT, ZP	6010662
25	4	5/16-18UNC FLANGED HEX NUT, SERRATED, ZP	6010661

PARTS LIST — CONTROL BOX

Fig. 29

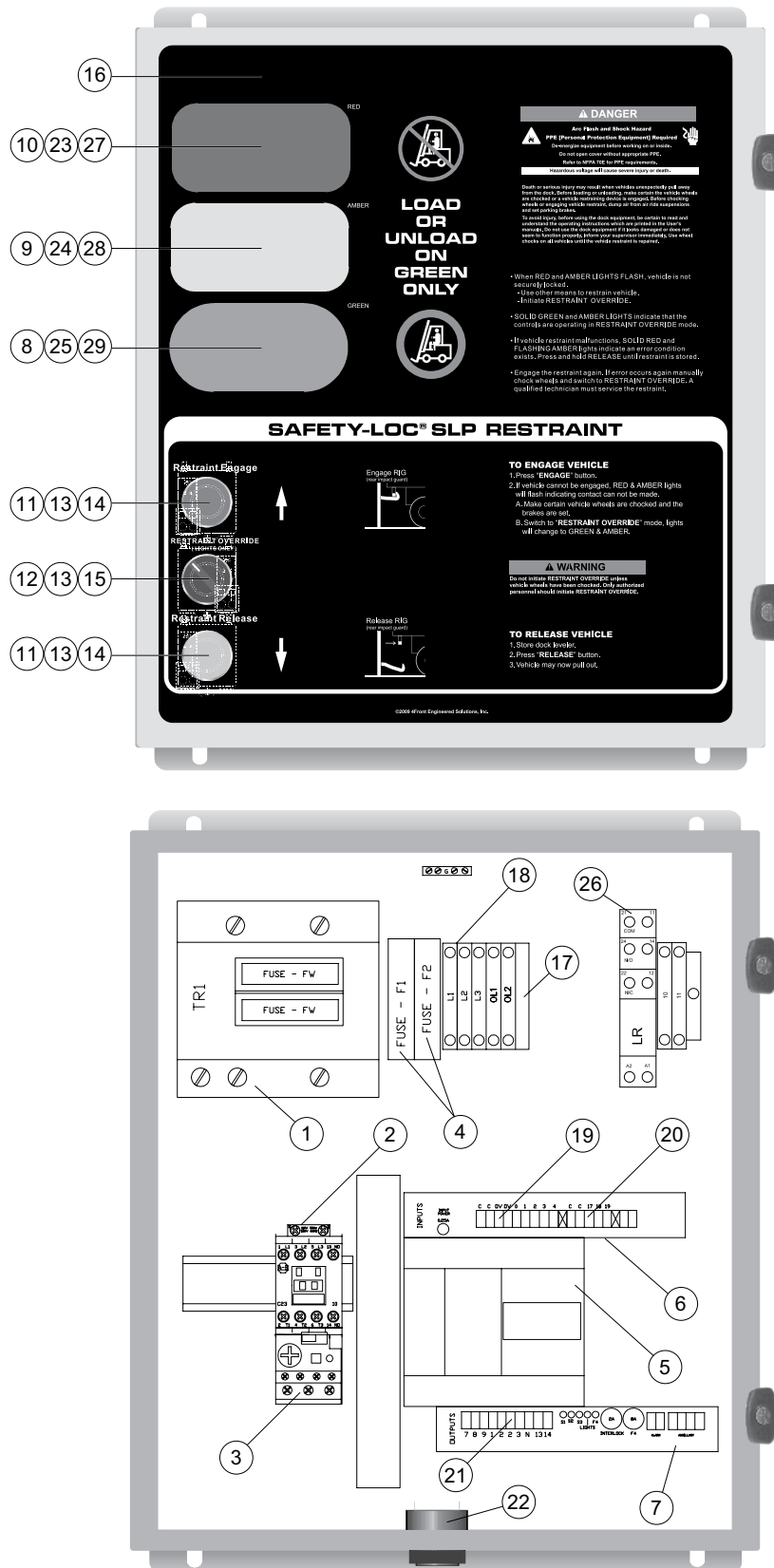

PARTS LIST — CONTROL BOX, continued

Item	Description	Kelley®								Part No.
		6003331V1	6003331V2	6003331V3	6003331V4	6003331V5	6003331V6	6003331V7	6003331V8	
		Serco®								
		120V 1Ph	208V 1Ph	240V 1Ph	208V 3Ph	240V 3Ph	380V/3/50	480V 3Ph	600V 3Ph	
1	Transformer 350VA, 120V to 24V	1								6000443
	Transformer 200VA, 208V to 24V		1		1					AP2775
	Transformer 200VA, 380V to 120V/24V						1			6001048
	Transformer 200VA 480/240V to 120V/24V			1		1		1		AP2773
	Transformer 200VA 600V to 120V/24V								1	AP2774
2	Contactora 18A, 24VAC coil 50/60 Hz	1								6000467
	Contactora 9A, 24VAC coil 50/60 Hz		1	1	1	1	1	1	1	6000457
3	Overload 12 - 18 amps	1								6000477
	Overload 9 - 13 amps		1	1						6000476
	Overload 4 - 6 amps				1	1	1			6000475
	Overload 2.5 - 4 amps							1	1	6000474
4	Fuse holder 1 pole**	1	2	2	2	2	2	2	2	6000557
5	PLC	1	1	1	1	1	1	1	1	6001056
6	Hydraulic restraint input board assembly	1	1	1	1	1	1	1	1	6003317
7	Hydraulic restraint output board assembly	1	1	1	1	1	1	1	1	6003318
8	Light base — oval	1	1	1	1	1	1	1	1	823111
9	Light base — amber, rectangle	1	1	1	1	1	1	1	1	823107
10	Light base — red, rectangle	1	1	1	1	1	1	1	1	823107
11	Push button, universal	2	2	2	2	2	2	2	2	6000506
12	Selector switch, spring return to left, 2 position	1	1	1	1	1	1	1	1	631219
13	Body, mounting collar	3	3	3	3	3	3	3	3	6000515
14	Block, contact, normally open	2	2	2	2	2	2	2	2	632228
15	Block, contact, normally closed	1	1	1	1	1	1	1	1	632229
16	Panel face label (Kelley®)	1	1	1	1	1	1	1	1	6001941
	Panel face label (Serco®)	1	1	1	1	1	1	1	1	6001940
17	Terminal, endplate	2	2	2	2	2	2	2	2	6000539
18	Terminal, 2 conductor	5	5	5	5	5	5	5	5	6000542
19	9 Pole female field terminal	1	1	1	1	1	1	1	1	6004803
20	5 Pole female field terminal	1	1	1	1	1	1	1	1	6004801

*2 each included in replacement bulb kit 637-144 LRU package

** See table on page 21 for Class CC fuse size.

PARTS LIST — CONTROL BOX, continued

Item	Description	Kelley®	6003331V2	6003331V3	6003331V4	6003331V5	6003331V6	6003331V7	6003331V8	Part No.
		Serco®	6003330V1	6003330V2	6003330V3	6003330V4	6003330V5	6003330V6	6003330V7	
		120V 1Ph	208V 1Ph	240V 1Ph	208V 3Ph	240V 3Ph	380V/3/50	480V 3Ph	600V 3Ph	
20	5 Pole female field terminal	1	1	1	1	1	1	1	1	6004801
21	10 Pole female field terminal	1	1	1	1	1	1	1	1	6006472
22	Audible alarm (optional)	1	1	1	1	1	1	1	1	6003335
23	Red LED	2	2	2	2	2	2	2	2	6006375
24	Amber LED	2	2	2	2	2	2	2	2	6006376
25	Green LED	2	2	2	2	2	2	2	2	6006377
26	110V outside light kit (optional)	1	1	1	1	1	1	1	1	6003336
27	Lens Only, Red, Rectangular	1	1	1	1	1	1	1	1	823100
28	Lens Only, Amber, Rectangular	1	1	1	1	1	1	1	1	823102
29	Lens Only, Green, Oval	1	1	1	1	1	1	1	1	AP0027

PARTS LIST — INPUT/OUTPUT BOARDS, continued

Fig. 30

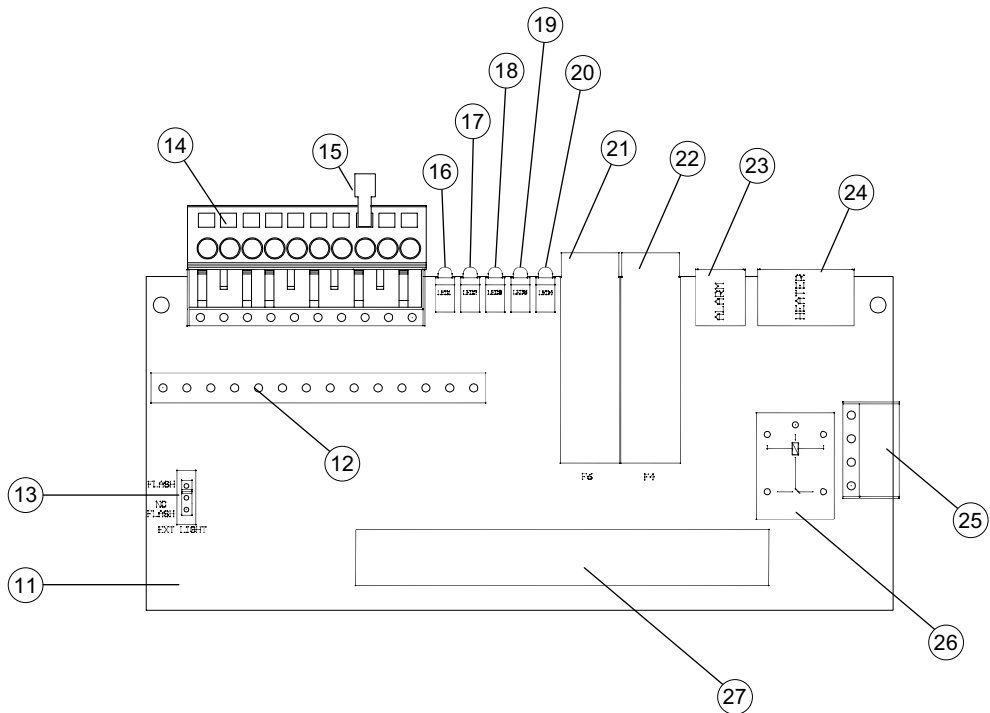
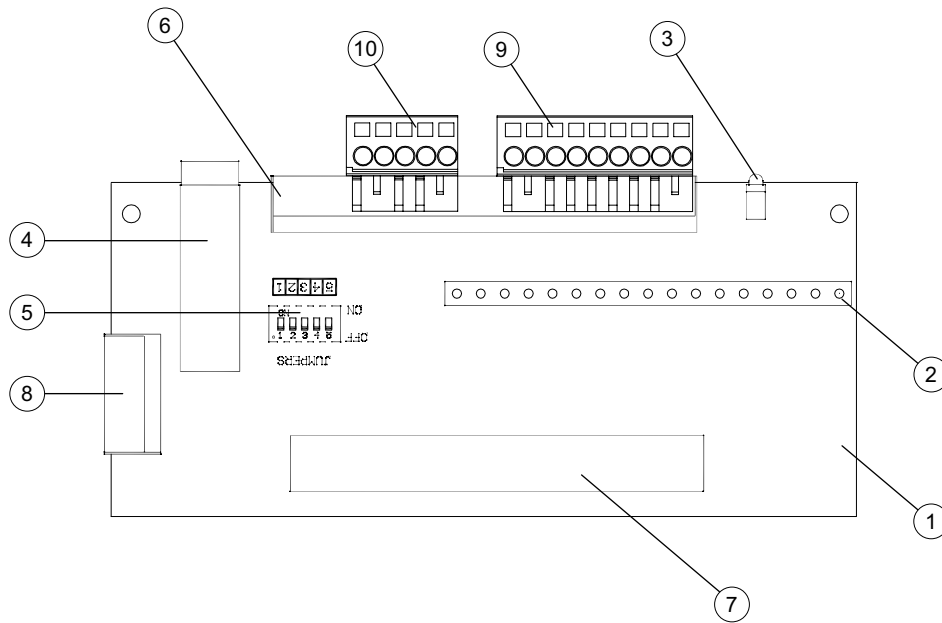

PARTS LIST — INPUT/OUTPUT BOARDS

Item	Quantity	Part Description	Part Number
1	1	Complete SLP/HH input card assembly	6003317
2	1	PLC interface header	
3	1	Input card power supply fuse LED	
4	1	Input card power supply fuse- 0.25A	3AG 0.25A
5	1	Dip Switch - Input option selection	
6	1	Field terminal connector	
7	1	Manufacturing Terminal connector	
8	1	Input expansion	
9	1	9 position field terminal block	6004803
10	1	5 position field terminal block	6004801
11	1	Complete SLP/HH output card assembly	6003318
12	1	PLC interface header	
13	1	Outside lights flasher control switch	
14	1	10 position field terminal block	6006472
15	1	Terminal opening tool	6004806
16	1	LED indicator - Solenoid 1	
17	1	LED indicator - Solenoid 2	
18	1	LED indicator - Solenoid 3	
19	1	LED indicator - Exterior Lights	
20	1	LED indicator - Main Board Power	
21	1	Fuse - Interlock	AGC 2A
22	1	Fuse - Main Board Power	AGC 8A
23	1	Alarm Output port	
24	1	Auxillary port	
25	1	expansion board interface port	
26	1	Solenoids 2 and 3 control relay	
27	1	Manufacturing Terminal connector	

PARTS LIST — OUTSIDE LIGHTS

Fig. 31

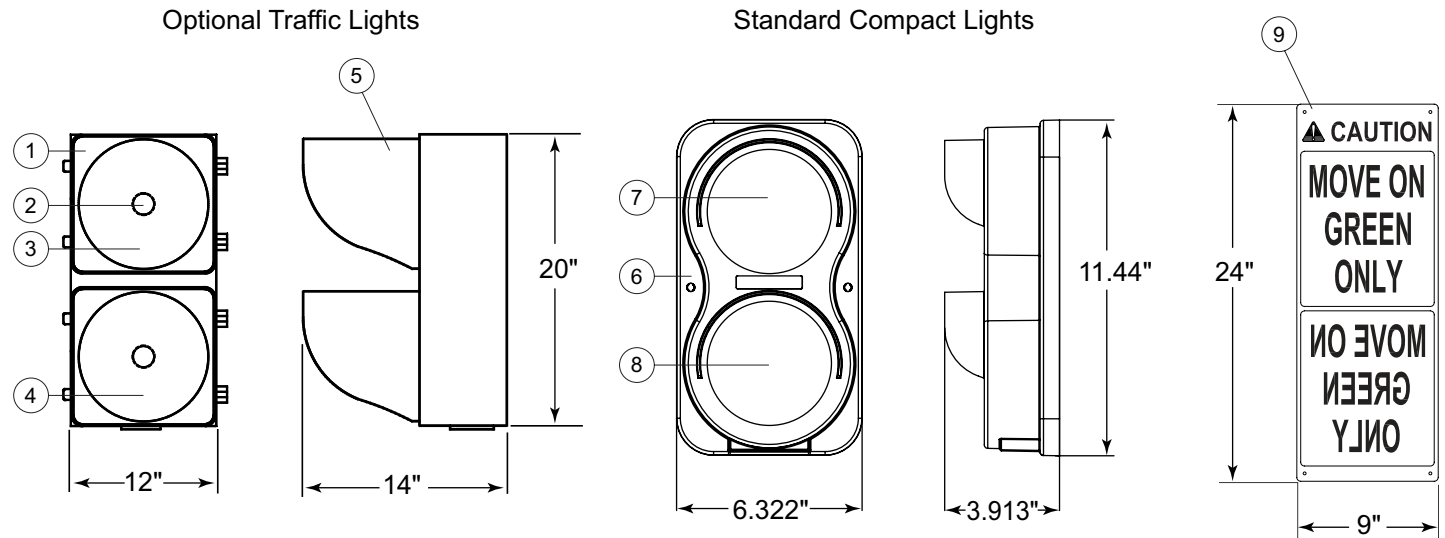

Item	Quantity	Description	Part Number
1	1	Light Assembly 120V - Complete (Includes items 2-5)	8-9519
2	2	Light Bulb 120V, 69 WATT	823-072
3	1	Lens - Red	823-043
4	1	Lens - Green	823-044
5	2	Visor	823-042
6	1	Light Assembly Complete (Compact Lights) 24V, LED (Includes items 7 and 8)	6007798
7	1	Red Light Assembly (LED)	6007800
8	1	Green Light Assembly (LED)	6007801
9	1	Sign - MOVE ON GREEN ONLY	709-832

LIMITED WARRANTY INFORMATION

4FRONT ENGINEERED SOLUTIONS® warrants that this VEHICLE RESTRAINT will be free from flaws in material and workmanship under normal use for a period of one (1) year from the earlier of 1) 60 days after the date of initial shipment by 4FRONT ENGINEERED SOLUTIONS®, or 2) the date of installation of the VEHICLE RESTRAINT by the original purchaser, provided that the owner maintains and operates the VEHICLE RESTRAINT in accordance with this User's Manual. In the event that this VEHICLE RESTRAINT proves deficient in material or workmanship within the applicable limited warranty period, 4FRONT ENGINEERED SOLUTIONS® will, at its option:

1. Replace the VEHICLE RESTRAINT, or the deficient portion of either, without charge to the owner (excluding any cost of removal or reinstallation which shall be the sole responsibility of the purchaser); or
2. Alter or repair the VEHICLE RESTRAINT, on site or elsewhere, without charge to the owner.

The limited warranty stated in the preceding paragraph IS EXCLUSIVE AND IT IS IN LIEU OF ANY OTHER GUARANTEES AND WARRANTIES, EXPRESS OR IMPLIED. The limited warranty does not cover any failure caused by improper installation, abuse, negligence, or failure to maintain and adjust the VEHICLE RESTRAINT properly. Parts requiring replacement due to damage resulting from vehicle impact, abuse, or improper operation are not covered by this warranty. 4FRONT ENGINEERED SOLUTIONS® disclaims any responsibility or liability for any loss or damage (including, without limitation, direct, indirect or consequential damages, or lost profits or production time) that results from the use of unauthorized replacement parts or modification of the VEHICLE RESTRAINT. 4FRONT ENGINEERED SOLUTIONS® sole obligation with regard to a VEHICLE RESTRAINT that proves to be deficient in material or workmanship shall be as set forth in its standard warranty above (i.e., 4FRONT ENGINEERED SOLUTIONS® will, at its option, repair or replace the VEHICLE RESTRAINT or portion thereof, without charge to the purchaser.).

This limited warranty does not cover any failure caused by improper installation, abuse, negligence, or failure to properly maintain and adjust the VEHICLE RESTRAINT. This limited warranty will be void or of no effect if the original purchaser does not notify 4FRONT ENGINEERED SOLUTIONS® warranty department within ninety (90) days after the product deficiency is discovered. Parts requiring replacement due to damage resulting from vehicle impact, abuse, or improper operation are not covered by this warranty. 4FRONT ENGINEERED SOLUTIONS® disclaims any responsibility or liability for any loss or damage that results from the use of unauthorized replacement parts or modification of the VEHICLE RESTRAINT.

THERE ARE NO WARRANTIES, EXPRESS OR IMPLIED, WHICH EXTEND BEYOND THE DESCRIPTION ON THE FACE HEREOF, AND THERE IS NO WARRANTY OF MERCHANTABILITY OR OF FITNESS FOR A PARTICULAR PURPOSE.

4FRONT ENGINEERED SOLUTIONS® warranties extend only to the VEHICLE RESTRAINT itself.

4FRONT ENGINEERED SOLUTIONS® DISCLAIMS all warranties, express or implied, responsibility or liability for loss or damage of any kind associated with the installation or maintenance of the VEHICLE RESTRAINT, including any liability for premature product wear, product failure, property damage or bodily injury arising from improper installation or maintenance of the VEHICLE RESTRAINT.

Please direct questions about your vehicle restraint to your local distributor.

Your local distributor is:

Cisco, Inc
800-968-8651
www.cisco-inc.com

Corporate Head Office:

1612 Hutton Dr. Suite 140
Carrollton, TX. 75006
Tel. (972) 466-0707
Fax (972) 323-2661