

AB Air-Powered

DOCK LEVELER SPECIFICATIONS

30K-50K LB. (15.8-22.7 KG) CAPACITY RATINGS

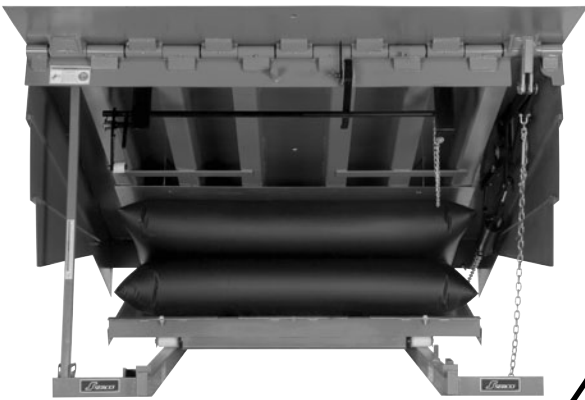

* Shown with optional Reflex anti-stump out legs

Design Highlights

- Exclusive SafeTFrame™ Design
- High Volume, Low Pressure Lifting System
- Low Maintenance Design
- Exclusive HYDRA CAM™ Plus Automatic Lip Extension
- High Tensile Steel Lip, Deck & Beams
- NEMA 4x Non-Metallic Push-button Control Panel (Non-Interlock Capable)
- 120V Single Phase Operation
- CLEAN FRAME® Design
- Structural Steel Safety Legs
- Full Operating Range Toe Guards
- Below-dock Endloading Capability
- 16" Lip Standard (406 mm)
- Grease Fittings
- Integral Maintenance Strut & Lip Support Latch
- Heavy-duty B410-14F Dock Bumpers
- Reduced Lip Crown/Extended Lip Chamfer

Project Information

Job Name _____
Address _____
General Contractor _____
Distributor _____
Model _____ Quantity _____ Voltage/Phase 120/1/60

Certified For Construction

By _____
Company _____
Address _____
Date _____

Available Options

- Factory Installed Brush Weatherseal
- Factory Installed Neoprene Weatherseal
- ENERGY GUARD® Perimeter Weatherseal System
- 18" Lip (457 mm)
- 20" Lip (508 mm)
- Lip Taper _____ (specify)
- 24" (610 mm) Pit Conversion
- Spray Foam Insulated Deck
- Galvanized Finish (Deck, Lip & Subframe Only) (40K and above)
- Special Paint Color
- Interlock Capable Control Panel (Non-Metallic)
- Structural Steel Safety Legs with Reflex™ Anti-Stump Out System (Shown)
- High Lip Crown
- Box Option:
For installation without pre-formed concrete pits, dock leveler supplied with integral pre-formed steel box for pour-in-place construction. Leveler shall be in an enclosed steel box structure complete with its own six-piece, welded structural curb angles and concrete anchors. The leveler is to be concreted in place as the floor is poured.
- Other _____



Box Option

Accessories

- PitBull® SAFETY-LOC® Restraint _____
- SLP Recessed Restraint
- MANUAL SAFETY-CHOCK Wheel Restraint
- SAFETY-CHOCK® Wheel Restraint
- Universal Truck-Chock™ Wheel Restraint
- ALS Light Communication System
- MLS Light Communication System
- Master Control Panel™
- Combination Control Panel

Bumper Options

- B410-14 VB420-11F
- B610-14 VB420-11 Steel Faced
- B610-14F Other _____

Capacity

- 30K lb (13.6 Kg) 35K lb (15.8 Kg)
- 40K lb (18 Kg) 45K lb (20.4 Kg)
- 50K lb (22.7 Kg)



AB Air-Powered

DOCK LEVELER SPECIFICATIONS

30K-50K LB. (15.8-22.7 KG) CAPACITY RATINGS

NOMINAL DIMENSIONS

MODEL	WIDTH	LENGTH
AB600	6' (1.83 m)	6' (1.83 m)
AB66.500	6'6" (2.01 m)	6' (1.83 m)
AB6700	7' (2.13 m)	6' (1.83 m)
AB800	6' (1.83 m)	8' (2.44 m)
AB86.500	6'6" (2.01 m)	8' (2.44 m)
AB8700	7' (2.13 m)	8' (2.44 m)
AB1000	6' (1.83 m)	10' (3.05 m)
AB106.500	6'6" (2.01 m)	10' (3.05 m)
AB10700	7' (2.13 m)	10' (3.05 m)

*24" (610 mm) pit depth standard on
10' (3.05 m) dock levelers

- General:** "AB" series dock leveler with air-powered platform and automatic lip extension. Unit conforms to ANSI MH14.1-1987 performance requirements. Unit to be manufactured by Serco.
- Construction, Platform Assembly:** Platform constructed of high tensile steel safety tread deck plate supported by high tensile steel beams fully welded to front header. "L" beam construction for 35K lb (15.8 Kg) split box beam construction for 40K-50K lb (18-22.7 Kg) capacity units. Deck to be 1/4" (6 mm) thick on 30K-45K lb (13.6-20.4 Kg) capacities and 3/8" (10 mm) thick on 50K lb (22.7 Kg) capacity.
- Lip Assembly:** Lip to be 16" (406 mm) high tensile steel safety tread lip plate with beveled leading edge. Lip to be 5/8" (16 mm) thick on 30K-45K lb (13.6-20.4 Kg) capacity units, and 3/4" (19 mm) thick on 50K lb (22.7 Kg) capacity units. 7' (2.13 m) wide lip tapers to 6'-6" (2.01 m) at leading edge (6'-0" (1.83 m) taper optional). Lip hinge to have full width structural front header and heavy wall tubing with a minimum of 3/16" (406 mm) wall thickness on 35K lb (15.8 Kg) and 1/2" (12 mm) wall thickness on 40K-50K lb (18-22.7 Kg) capacity units. Hinge tubes to have gussets on 35K, 45K & 50K lb (15.8, 20.4 & 22.7 Kg) capacity units. Lip hinge shaft to be a minimum of 1" (25 mm) solid steel on 35K lb. (15.8 Kg) and 1-1/4" (31 mm) on 40K-50K lb (18-22.7 Kg) capacity units.
- Lip Extension:** Patented HYDRA CAM™ Plus lip assist mechanism automatically extends lip at top of raising cycle.
- Rear Subframe & Hinge:** Rear structural frame consists of a welded structure constructed from 4 structural angle vertical members connecting two horizontal members. The upper rear angle has longitudinal support gussets & additional deck supports to promote structural stiffness. The hinge system consists of four 3/4" (19 mm) thick lugs allowing 4" (100 mm) of side to side deck twist.
- SafeTFrame™:** Adjustable shim system consisting of four independently operated leveling feet capable of 1-1/2 inches (37.5 mm) of vertical adjustment each. System eliminates the need for installer to place and weld steel shim stock under the vertical uprights providing more consistent installation thus preventing a gap or (bump) between the rear transition angle and curb angle.
- Power Unit:** Power unit is an electric motor and blower.
- Electrical:** Motor is 120V single phase. Power unit is mounted to galvanized pan subassembly (elevated off pit floor).
- Control Panel:** Non-metallic, non-interlock capable, single push-button control panel. Optional interlock capable control panel available.
- Product Finish:** Enamel gray finish.
- CLEAN FRAME®:** Unique design allows access for easy pit clean out and routine maintenance.
- Lip Extension:** Lip will extend automatically at top of raising cycle.
- "Nite-Lock":** Permanent "Nite-Lock" to prevent unauthorized entry beneath locked overhead door is standard.
- Structural Center Deck Support:** Standard center beam support (5" (127 mm) structural channel) to reinforce leveler for 3-wheel lift truck traffic is on 40K-50K lb (18K-22K Kg) capacities.
- Toe Guard Protection:** Full operating range toe guard protection is provided on the sides of the leveler. Yellow OSHA required markings IAW ANSI Z535.1 provided on the sides of the dock leveler.
- Safety Legs:** Structural safety legs provide emergency support should a truck depart with a load on the leveler platform. Optional Reflex design incorporates cam mechanism to limit interference from truck float.
- Integral Maintenance Strut & Lip Support Latch:** A permanently mounted, hinged, lockout capable maintenance strut and lip support latch are provided to support the lip and leveler during routine maintenance and pit cleaning.
- Below-dock Control (Endloading):** Push-button control and front mounted lanyard facilitate below-dock endloading.
- Out of Level Compensation:** Leveler platform on all capacities is designed to compensate for canted truck beds up to 4", while the rear of the deck remains flush with the pit.
- Float Compensation:** Allows for vertical carrier deflection when lip is in contact with truck bed.
- Operation:** Serco's "AB" Air Bag Leveler shall be supplied completely assembled with platform; lip; power unit; including motor. To operate leveler, dock attendant presses "RAISE" button, platform raises and hinged lip automatically extends. When button is released, platform descends until lip is supported by the truck bed and floats with truck movement. To restore leveler, dock attendant presses "RAISE" button and lip retracts as platform raises. Standard below-dock level operation allows for below-dock endloading with push-button control and lanyard. Working range to be 12" (305 mm) above-dock and 12" (305 mm) below-dock for 6' (1.83 m), 8' (2.44 m), and 10' (3.05 m) long units. The lip extends a minimum of 11" (279 mm) beyond the face of a 4" (100 mm) bumper.
- Installation:** Unit shipped completely assembled and ready for installation in pre-formed concrete pit. Pit depth is 20" (508 mm) for 6' (1.83 m) and 8' (2.44 m) long units, 24" (610 mm) for 10' (3.05 m) long units. Pit construction to be in accordance with certified Serco pit detail drawings. Contact Serco for current cost and nearest distributor.
- Limited Warranty:** Limited parts & labor warranty on all components under normal use for a 1-year "Base Warranty Period" beginning on the completion of installation or the sixtieth (60th) day after shipment, whichever is earlier. Additional 4-year parts & labor warranty on lifting system (air bag, motor, hoses, gaskets, fittings, & seals). Limited prorated 10-year structural warranty available upon engineering approval of written application.
- Bumpers:** Unit to include two model B410-14F (4" Thick x 14" W x 10" H) (100 mm x 356 mm x 254 mm) heavy-duty bumpers.



Standard Single
Push-button Control Panel

SERCO®