



NEMA 5-15R receptacle for Air Activated levelers must be flush mounted and wiring through the push button station as per the User's Manual wiring diagrams.

For solar applications see approval drawings for all conduit information.

TYP > 1/4" / 3

DOCK FLOOR

ALL CURB ANGLE JOINTS TO BE WELDED SECURELY

IMPORTANT - Concrete behind Pit Steel must be well vibrated. 8" recommended minimum thickness for Pit Walls, Pit Floor and Dock Face.

For dock heights under 46" or over 52" consult factory.



PIT LAYOUT DETAILS

For Air Activated Units Only - Set Conduit (3/4") and Receptacle (by Others) Before Pouring Concrete.

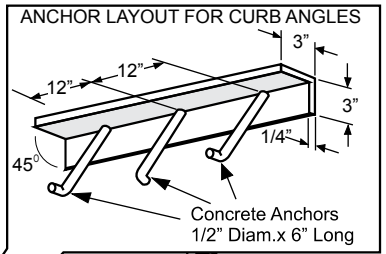

DIM.B

DIM.A

DIM.D

Rear Pit Wall to be plumb Reverse Slope of 1/4" is permissible.

IMPORTANT - Side Curb Angles must be 90 degrees to Dock Face and to Rear Curb.

DIM.C

1/2" PITCH

WALL

PIT FLOOR

WALL

CONTROL PANELS (INSIDE WALL)

Power to the dock leveler control panel must be from a 20 A max. circuit breaker. (Supplied by Others)

Safety Loc Control Panel (Optional)

Dock Leveler Control Panel

60" From Dock Floor

Branch Tee

Attach to stub

3/4" conduit, 6" stub out

Safety-Loc® PitBull® (Optional) Set conduit (3/4") and junction box (by others) before pouring concrete.

See reverse side for face curb angle details.

(OPTIONAL) BUMPER MOUNTING PLATE

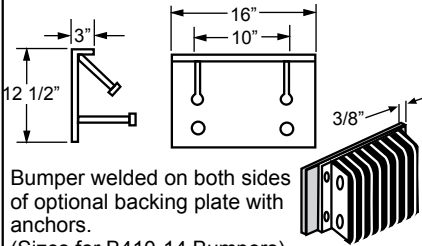

(OPTIONAL) SAFETY-LOC® PITBULL® MOUNTING PLATE

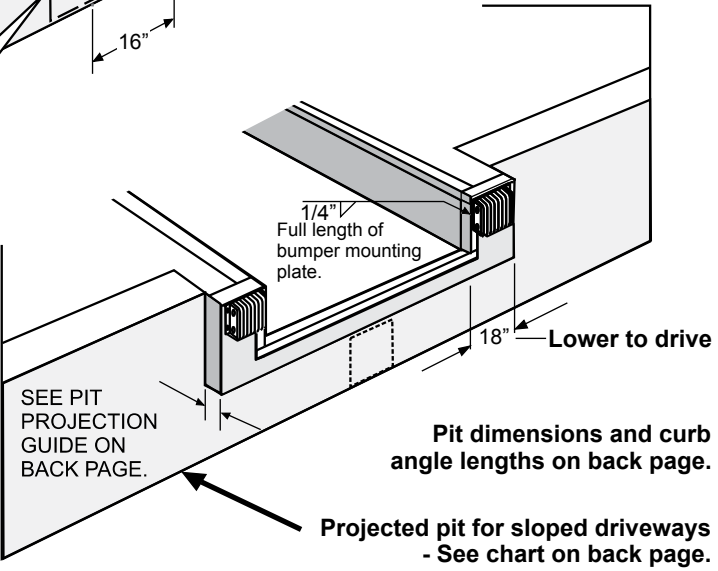
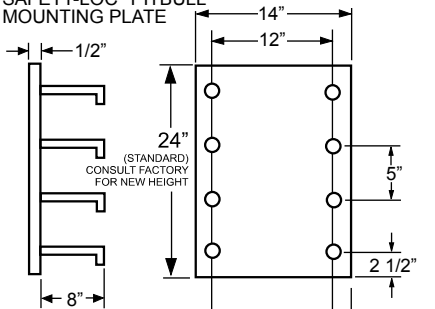

Pit dimensions and curb angle lengths on back page.

PROJECT INFORMATION

Job Name _____

Address _____

General Contractor _____

Serco Distributor _____

Quantity _____ Voltage _____

Dock Leveler Model _____

CONSTRUCTION APPROVAL

Company _____

Address _____

By _____

Date _____

NOTICE

Pit Dimensional Tolerances are +/- 1/8" on squareness, Depth, Width and Length.
 SERCO Assumes No Liability for Deviations beyond this Tolerance.



**DIMENSIONS BELOW ARE FOR ALL AB PIT TYPE LEVELERS OF 30-45K CAPACITIES.
 DIM "C" IS 24" AND DIM "D" IS 23 1/2" FOR 5', 6' & 8' LONG LEVELERS PLACED IN 24" DEEP PITS WITH OPTIONAL RISER KIT.**

MODEL	PIT DIMENSIONS				CURB ANGLE LENGTHS				
	DIM "A"	DIM "B"	DIM "C"	DIM "D"	REAR (1)	FRONT (1)	SIDE (2)	FACE	BUMPER
6' x 6'	63"	73"	20"	19-1/2"	79"	79"	60"	17"	21"
8' x 6'	87"	73"	20"	19-1/2"	79"	79"	84"	17"	21"
10' x 6'	111"	73"	24"	23-1/2"	79"	79"	108"	21"	21"
6' x 6'6"	63"	79"	20"	19-1/2"	85"	85"	60"	17"	21"
8' x 6'6"	87"	79"	20"	19-1/2"	85"	85"	84"	17"	21"
10' x 6'6"	111"	79"	24"	23-1/2"	85"	85"	108"	21"	21"
6' x 7'	63"	85"	20"	19-1/2"	91"	91"	60"	17"	21"
8' x 7'	87"	85"	20"	19-1/2"	91"	91"	84"	17"	21"
10' x 7'	111"	85"	24"	23-1/2"	91"	91"	108"	21"	21"

***NOTE - CURB ANGLES SUPPLIED BY OTHERS**

PIT PROJECTION GUIDE FOR DECLINE DRIVE CONDITIONS

PERCENTAGE OF DRIVEWAY GRADE	0%	1%	2%	3%	4%	5%	6%	7%	8%	9%	10%
PIT PROJECTION	0"	2"	3"	4"	5"	6"	8"	9"	10"	11"	12"

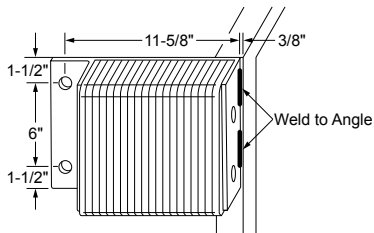

- 2 MODEL B410-14F LAMINATED BUMPERS - STANDARD FOR 30-50K
- 2 MODEL B610-14F LAMINATED BUMPERS - OPTIONAL FOR 60-80K

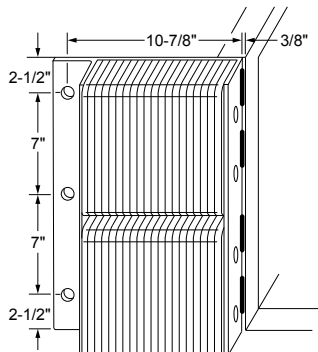

- 2 MODEL VB420-11F LAMINATED BUMPERS - OPTIONAL FOR 30-50K
- 2 MODEL VB620-11F LAMINATED BUMPERS - OPTIONAL FOR 60-80K

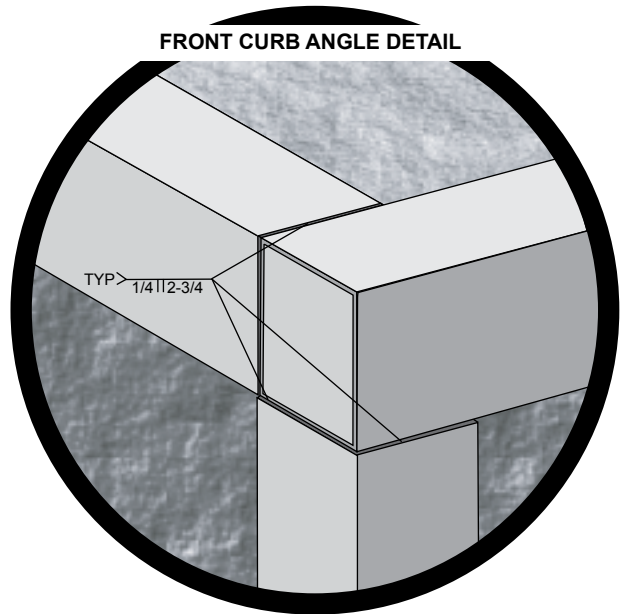

DISTRIBUTED BY: